



**GE Security**

466-2182 Rev. C  
September 2005

[www.gesecurity.com](http://www.gesecurity.com)

**Part Numbers:**

**600-1021-95R**

**600-1022-95R**

**600-1040**

**600-1042**

# Concord 4 Series Security Systems

---

## Installation Instructions

## Notices

### FCC Part 15 Information to the User

Changes or modifications not expressly approved by GE Security can void the user's authority to operate the equipment.

### FCC Part 15 Class B

This equipment has been tested and found to comply with the limits for a Class B digital device, pursuant to part 15 of the FCC Rules. These limits are designed to provide reasonable protection against interference in a residential installation.

This equipment generates, uses, and can radiate radio frequency energy and, if not installed and used in accordance with the instructions, may cause harmful interference to radio communications. However, there is no guarantee that interference will not occur in a particular installation.

If this equipment does cause harmful interference to radio or television reception, which can be determined by turning the equipment off and on, the user is encouraged to try to correct the interference by one or more of the following measures:

- Reorient or relocate the receiving antenna.
- Increase the separation between the equipment and receiver.
- Connect the affected equipment and the panel receiver to separate outlets, on different branch circuits.
- Consult the dealer or an experienced radio/TV technician for help.

### ACTA Part 68

This equipment complies with Part 68 of the FCC Rules and the requirements adopted by the ACTA. Located on this equipment is a label that contains, among other information, the registration number and the ringer equivalence number (REN) for this equipment. If requested, this information must be provided to the telephone company.

Registration No. US:B4ZAL01B60095R

The REN is used to determine the maximum number of devices that may be connected to your telephone line. Excessive RENs on a telephone line may result in devices not ringing in response to an incoming call. In most areas, the sum of all device RENs should not exceed five (5.0). To be certain of the number of devices that may be connected to a line, as determined by the total RENs, contact the local telephone company. For products approved after July 23, 2001, the REN for this product is part of the product identifier that has the format US:AAAEQ##TXXXX. The digits represented by ## are the REN without a decimal point (e.g., 03 is a REN of 0.3). For earlier products, the REN is separately shown on the label.

A plug and jack used to connect this equipment to the premises wiring and telephone network must comply with the applicable FCC Part 68 rules and requirements as adopted by ACTA. A compliant telephone cord and modular plug is provided with this product. It is designed to be connected to a compliant modular jack that is also compliant. See the Installation Instructions for details.

Alarm dialing equipment must be able to seize the telephone line and place a call in an emergency situation. It must be able to do this even if other equipment (telephone, answering system, computer modem, etc.) already has the telephone line in use. To do so, alarm dialing equipment must be connected to a properly installed RJ31X jack that is electrically in series and ahead of all other equipment attached to the same telephone line. Proper installation is depicted in the following diagram. If you have any questions concerning these instructions, consult your local telephone company or a qualified installer about installing an RJ31X jack and alarm dialing equipment for you.

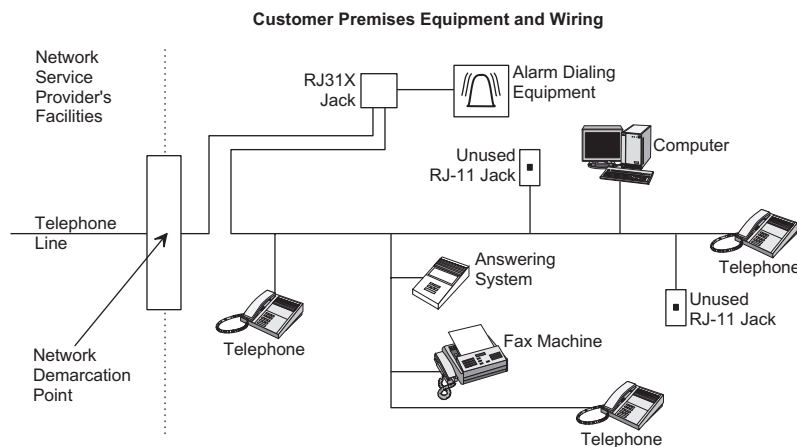

If this equipment causes harm to the telephone network, the telephone company may temporarily disconnect your service. If possible, you will be notified in advance. When advance notice is not practical, you will be notified as soon as possible. You will also be advised of your right to file a complaint with the FCC.

The telephone company may make changes in its facilities, equipment, operations, or procedures that could affect the operation of the equipment. You will be given advance notice in order to maintain uninterrupted service.

If you experience trouble with this equipment, please contact the company that installed the equipment for service and/or repair information. The telephone company may ask you to disconnect this equipment from the network until the problem has been corrected or you are sure that the equipment is not malfunctioning.

This equipment may not be used on coin service provided by the telephone company. Connection to party lines is subject to state tariffs.

### Patent Information

This product and the use of this product may be covered by one or more of the following patents: 5,805,063, 5,872,512, 5,942,981, 5,686,896, 5,686,885, 4,855,713. Except expressly provided herein, the purchase of this product shall not constitute a license or otherwise provide a right to practice a method covered by any of the identified patents. GE Security hereby grants the purchaser of this product a limited, non-exclusive license to practice the methods patented in the identified patents solely with products manufactured, sold or licensed by GE Security. This license grant does not extend to the use of unlicensed, third party products with this product.



**GE Security**

1275 Red Fox Road, Arden Hills, MN 55112  
Technical Support: 800-777-2624

©2003 GE Security. Concord is a trademark of GE Security. SuperBus is a registered trademark of GE Security. All other trademarks are properties of their owners. All rights reserved.

# Contents

## **About This Manual 1**

About the User's Guide .....	1
Special Installation Requirements .....	1
UL Listed Installations .....	1
Basic System .....	1
Household Burglary Alarm System Unit (UL 1023) .....	1
Household Fire Warning System (UL 985) .....	2
UL 1023 & 985 24-Hour Backup .....	2
SIA System Requirements .....	2
SIA Setting Requirements .....	2
Commercial Burglary Alarm System Unit (Grade B UL 1610) .....	3
UL 1610 24-Hour Backup .....	3
UL 1635 Digital Alarm Communicator System .....	3
Central Station Reporting .....	4
UL Canada Listed Installations .....	4
Canadian Standards CSA Certified Accessories .....	4
Residential Burglary Alarm System Unit (ULC Subject C1023-1974) .....	4
Residential Fire Warning System Control Unit (ULC-S545-M89) .....	4
California State Fire Marshall Listed Installations .....	4

## **Planning the Installation 4**

Standard Panel .....	4
SuperBus 2000 Touchpads .....	5
SuperBus 2000 RF Transceiver .....	5
SuperBus 2000 RF Receiver .....	5
Power Line Carrier Transformer .....	5
SuperBus 2000 Voice Only Module .....	5
SuperBus 2000 Phone Interface/Voice Module .....	5
SnapCards .....	6
SuperBus 2000 8Z Input Module (HIM) .....	6
SuperBus 2000 4-Relay Output Module (HOM) .....	6
Interrogator 200 Audio Verification Module .....	6
SuperBus 2000 Cellular Backup Module .....	6
SuperBus 2000 Energy Saver Module (ESM) .....	6
SuperBus 2000 Automation Module .....	6
SuperBus 2000 Wireless Gateway-Ready Kit .....	6
SuperBus 2000 2 Amp Power Supply .....	6

## **Installing the System 6**

Determine the Panel Location .....	7
Total System Power and Wire Length Guidelines .....	7
Power .....	7
Wire Length .....	7
Mounting the Panel .....	9

## **Identify Panel Components 10**

Installing Antenna Shrouds .....	10
Connecting the Panel to Earth Ground .....	11
Installing Optional SnapCards .....	11
Connecting Detection Devices to Panel Zone Inputs .....	11
Connecting Intrusion Detection Devices .....	11
Connecting 2-Wire Smoke Detectors .....	12
Connecting 4-Wire Smoke Detectors .....	13
Connecting Speakers .....	13
15-Watt Speaker (13-060) .....	13
Hardwire Interior Speaker (60-528) .....	14

Connecting Exterior/Interior Piezo Sirens .....	14
Output 1 .....	14
Piezo Dynamic Exterior Siren (13-950) .....	14
Output 2 .....	15
Hardwire Interior Siren (13-949) .....	15
Connecting an Interrogator 200 Audio Verification Module (60-677) .....	15
Connecting SuperBus 2000 Touchpads .....	16
Installing SuperBus 2000 Modules .....	16
Mounting Modules Inside the Panel Enclosure .....	16
SuperBus 2000 2 Amp Power Supply (600-1019) .....	17
SuperBus 2000 Transceiver Module (600-1025-01-95R) and SuperBus 2000 RF Receiver Module (60-764-95R-01) .....	17
SuperBus 2000 Voice Only Module .....	17
SuperBus 2000 Phone Interface/Voice Module (60-777-01) .....	18
Wiring for Status Voice Messages Only .....	18
Wiring for Status and Alarm Messages .....	19
SuperBus 2000 Energy Saver Module (60-620-01) .....	19
SuperBus 2000 8Z Input Module (60-774) .....	19
SuperBus 2000 4-Relay Output Module (60-770) .....	19
SuperBus 2000 Cellular Backup Module .....	20
SuperBus 2000 Automation Module (60-783-02) .....	21
SuperBus 2000 Wireless Gateway-Ready Kit (600-1010) .....	21
Installing an RJ-31X Phone Jack (13-081) .....	21
Connecting the Phone Line to the Panel with a DB-8 Cord .....	22
Connecting the AC Power Transformer .....	22
Powering Up the Panel .....	23

## ***Programming the Panel***

**23**

Entering Program Mode .....	23
Touchpad Button Programming Functions .....	24
Moving Through Program Mode Tiers and Menus .....	24
Programming Tier 1 Menu Items .....	25
Demo Kit Mode (System Programming) .....	25
Partition 1 Copy (System Programming) .....	25
Clear Memory (System Programming) .....	26
Programming Tier 2 Menu Items .....	26
Using Shortcut Numbers .....	26
Security Menu .....	26
Partition Security (0004) .....	27
Multi-Partition Arm/Disarm (0005) .....	28
Keychain TP PTN (0006) .....	29
Exit Extension (0013 - 0063) .....	30
Duress Code (0016 - 0066) .....	31
Phones Menu 31	
Phone Options Menu .....	35
Dialer Abort Delay (02006) .....	36
Cancel Message (02007) .....	37
Call Wait Cancel (02009) .....	37
Timers Menu .....	39
Entry Delay (0310 - 0360) .....	41
Exit Delay (0311 - 0361) .....	41
Extended Delay (0312 - 0362) .....	41
Light Control Menu .....	42
Touchpad Options Menu .....	43
Reporting Menu .....	44
Swinger Limit (06015) .....	47
Alarm Verify (06108 - 06608) .....	49

Siren Options Menu .....	50
Sensors Menu .....	51
Audio Verification Menu .....	54
Accessory Modules Menu .....	56
Onboard Options Menu .....	59
Smoke Verify (1100) .....	60
Macro Keys Menu .....	61
Exiting Programming Mode .....	62
Entering Quick Programming Mode .....	62
Entering User Programming Mode .....	62
Time and Date Menu .....	63
User Codes Menu .....	63
Options Menu .....	65
Set Up Schedules Menu .....	66
Attach Schedules to Events Menu .....	67
Energy Saver Menu .....	69
Attach Lights to Sensors Menu .....	69
System Version Menu .....	70
Downloader Programming .....	70
Enterprise Downloader Programming .....	70
<b>Testing the System</b> .....	<b>70</b>
Basic System Commands .....	71
Testing Zones/Sensors .....	71
If a Wireless Sensor Does Not Test .....	72
Testing Phone Communication .....	72
Testing Central Station/Pager Communication .....	72
Testing Outputs and Sirens .....	73
Testing Light Control .....	74
Testing the Energy Saver Module (ESM) .....	74
Changing Fixed Display LCD Touchpad Chime and Trouble Beep Tones .....	74
Adjusting Touchpad Display Contrast .....	74
Testing Audio Verification Module (AVM) Communication .....	74
Testing Cellular Backup Communication .....	75
<b>Troubleshooting</b> .....	<b>76</b>
<b>Appendix A: System Planning Worksheets</b> .....	<b>82</b>
<b>Appendix B: Reference Tables</b> .....	<b>90</b>
Cross-Zoning .....	91
Notes for Table B8: Response Numbers .....	98
<b>Appendix C: Settings</b> .....	<b>99</b>
<b>Appendix D: Software Release Notes</b> .....	<b>106</b>
<b>Specifications</b> .....	<b>106</b>
<b>System Wiring Notes</b> .....	<b>107</b>

---

## About This Manual

This manual provides information for planning, installing, programming, and testing this security system. When necessary, this manual refers you to other documentation included with compatible peripherals.

Planning sheets are included for you to record hardware layout and software programming settings.

### **About the User's Guide**

The *User's Guide* (466-2183) contains user worksheets that should be filled out during the installation and programming of the system. For multi-partition systems, a *User's Manual* for each partition is suggested.

### **Special Installation Requirements**

This security system can be used as a fire warning system, an intrusion alarm system, an emergency notification system, or any combination of the three.

Some installations may require configurations dictated by city/state codes, insurance, or Underwriter's Laboratories (UL). This section describes the various component and configuration listings.

### **UL Listed Installations**

This section describes the requirements for UL Listed installations.

#### **Basic System**

- Control Panel (600-1021-95R Concord 4 RF, 600-1022-95R Concord Express V4, 600-1040 Concord Commercial V4, or 600-1042 Concord 4 Hybrid)
- Standard Class II 16.5 VAC, 40 VA power transformer 22-145 (order #600-1023) or 22-145-CN (order #600-1023-CN), or Power Line Carrier Class II 16.5 VAC, 40 VA power transformer 22-149 (order #600-1024) or 22-149-CN (order #600-1024-CN). These transformers must be ordered separately from GE Security.
- Backup Battery 12V 4.5 Ah (60-681) or 12V 7 AH (60-680)
- SuperBus<sup>®</sup> 2000 Fixed Display Touchpad (60-820), 2x16 LCD Touchpad (60-746-01), ATP1000 (60-983) ATP2100 (60-985), ATP 2600 (60-984), 2x20 LCD Touchpad (60-803), or 2x20 VFD Touchpad (60-804)
- Interior Speaker Siren (60-528), Hardwire Interior Siren (13-949), or Speaker Siren (13-060)

Basic system may also include a SuperBus 2000 RF Receiver (60-764-95R-01) or a SuperBus Transceiver (600-1025-01-95R).

#### **Household Burglary Alarm System Unit (UL 1023)**

Basic system, plus:

- Hardwire Magnetic Contact (13-068 or 13-071) or Wireless Learn Mode Door/Window Sensor (60-362)
- Immediate Beeps set to on
- UL 98 Options set to on
- Receiver Failure set to on (if wireless devices are used)
- Siren Verify set to on
- Exit Delay set to 60 seconds
- Quick Exit set to off
- Siren Timeout set to 4 minutes or more
- Entry Delay set to 45 seconds or less
- RF TX Timeout set to 24 hours (if system includes a built in receiver or SuperBus 2000 RF Receiver or SuperBus 2000 RF Transceiver and wireless burglary sensors)
- Extended Delay set to off
- Sleep Time set to off
- Two Trip Error set to off
- Alarm Verify set to off
- Disable Trouble Beeps set to off

### Household Fire Warning System (UL 985)

Basic system, plus:

- Hardwire Smoke Detector: *System Sensor models* 2400 or 2400TH learned into sensor group 26 or *Sentrol (ESL) models* 429AT, 521B or 521BXT learned into sensor group 26
- Wireless Smoke Sensor 60-506-319.5 or 60-848-02-95 learned into sensor group 26
- Immediate Beeps set to on
- UL 98 Options set to on
- Receiver Failure set to on (if wireless devices are used)
- Siren Verify set to on
- RF TX Timeout set to 4 hours (if system includes a built in receiver or SuperBus 2000 RF Transceiver and wireless smoke sensors)
- Sleep Time set to off
- Siren Timeout set to 4 minutes or more
- Two Trip Error set to off
- Disable Trouble Beeps set to off

### UL 1023 & 985 24-Hour Backup

For 24-hour backup, the total current draw for all connected devices is limited to 90 mA (during normal standby conditions) using a 4.5 Ah battery, or 190 mA (during normal standby conditions) using a 7.0 Ah battery.

### SIA System Requirements

SIA system requirements are the same as those described for a UL Listed Basic System on page 1, plus:

- If multiple annunciation is required, use additional touchpads. Model numbers 60-746-01, 60-803, 60-804, 60-820, 60-983, 60-984, 60-985.

### SIA Setting Requirements

The following table describes programming requirements to meet ANSI-SIA CP-01.

Shortcut #	Function	Programming Page Reference	Testing Page Reference	Default Setting	Required Setting
0013 - 0063	Exit Extension	29	70	On	On
0016 - 0066	Duress Code	30	70	Disabled	Disabled
02006	Dialer Abort Delay	35	70	30 Sec.	15-45 sec.
02007	Cancel Message	36	70	On	On
02009	Call Wait Cancel	36	70	Disabled	On if reporting to central station and customer has call waiting service
0310 - 0360	Entry Delay	40	70	30 sec.	30-240 sec.
0311 - 0361	Exit Delay	40	70	60 sec.	45-184 sec.
06015	Swinger Limit	46	70	1	1
1100	Smoke Verify	58	70	Off	On if smoke alarms are programmed into system
N/A	Cross Zoning	91	70	Disabled	Enabled for zones with a high probability of false alarms

The following table describes non-programmable (hard coded) system operation as required to meet ANSI-SIA CP-01 and is provided only for your reference.

Function	Operation
SIA False Alarm	Enabled
Auto Stay Arming	Enabled
Disarm During Entry Delay	Enter Code Only (or 1 + CODE)
Cancel Alarm	Enter Code Only (or 1 + CODE)
Abort Annunciation	Enabled
Entry/Exit Progress Annunciation	Enabled

**Note**

*Silent arming feature may be used to suppress arming level and exit beeps for the current arming period only. Refer to user guide for more information on silent arming.*

**Commercial Burglary Alarm System Unit (Grade B UL 1610)**

Basic system using Control Panel 600-1040, SuperBus 2000 RF Transceiver Module (600-1025-01-95R), plus:

- Hardwire Magnetic Contact (13-068 or 13-071) or Wireless Learn Mode Door/Window Sensor (60-499)
- SAW PIR Sensor (60-639-95R), Crystal PIR Sensor (60-703-95R), or DS924i PIR Sensor (60-511-01-95)
- UL Grade A Bell/Housing such as Ademco #AB12M or equivalent
- Immediate Beeps set to on
- UL 98 Options set to on
- Receiver Failure set to on (if wireless devices are used)
- RF TX Timeout set to 4 hours
- 24-Hour Tamper set to on
- System Tamper set to on
- Auto Phone Test set to on
- Phone Test Freq. set to 1
- Next Phone Test set to 1
- Siren Verify set to on
- AC Failure set to on
- Exit Delay set to 120 seconds or less
- Quick Exit set to off
- Two Trip Error set to off
- Alarm Verify set to off
- Disable Trouble Beeps set to off
- Phone Number must be programmed
- High Level Rpts set to on
- Low Level Rpts set to on
- Comm. Failure set to on
- Extended Delay set to off
- Sleep Time set to off
- Siren Timeout set to 4 minutes or more

**UL 1610 24-Hour Backup**

- Same as UL 1023 & 985

**UL 1635 Digital Alarm Communicator System**

Same as UL 1023, 985 & 1610 plus:

- AC Failure set to on
- Phone Number must be programmed
- Low CPU Battery set to on
- Next Phone Test set to 1

**Note**

*For UL 1635 installations, Entry Delay plus Dialer Abort Delay must not exceed 60 seconds.*



- Phone Test Freq. set to 1
- High Level Rpts set to on
- Low Level Rpts set to on
- Comm. Failure set to on
- RF Tx Timeout set to 4 hours

### Central Station Reporting

The panel has been tested with the following central station receivers using SIA and Contact ID reporting formats:

- CS-5000 Central Station Receiver
- Sur-Gard Central Station Receiver with models SG-DRL2A and SG-CPM2
- Osborne Hoffman Central Station Receiver

### UL Canada Listed Installations

This section describes the requirements for CUL (UL Canada) Listed installations.

#### Canadian Standards CSA Certified Accessories

#### Residential Burglary Alarm System Unit (ULC Subject C1023-1974)

Basic system as described for “UL 1023 Listed Installations” plus:

- Hardwire Magnetic Contact (13-068 or 13-071) or Wireless Learn Mode Door/Window Sensor (60-362)
- Siren Timeout set to 5 minutes or more

#### Residential Fire Warning System Control Unit (ULC-S545-M89)

Basic system as described for “UL 985 Listed Installations” plus:

- Hardwire Smoke Detector: *System Sensor models* 2400 or 2400TH learned into Sensor Group 26, or *Sentrol (ESL) models* 429AT, 521B, or 521BXT learned into sensor group 26
- Wireless Smoke Sensor 60-506-319.5 or 60-848-02-95 learned into sensor group 26
- Immediate Trouble Beeps set to on
- RF TX Timeout set to 4 hours (if system includes SuperBus 2000 RF Transceiver and wireless smoke sensors)
- Siren timeout set to 5 minutes or more.

#### California State Fire Marshall Listed Installations

Same as Household Fire Warning System (UL 985), plus:

- SMOKE VERIFY must be set to off

**Note**

The installer must verify the compatibility between this panel and the central station receiver(s) being used.

**Note**

For 24-hour backup, external power drain is limited to 90 mA (during normal standby condition) using a 4.5 Ah battery, or 190 mA continuous using a 7.0 Ah battery.

## Planning the Installation

This section describes system capabilities to help you get familiar with the system. “Appendix A” provides planning sheets with tables that let you record the hardware and programming configuration of the system. Fill in all necessary information ahead of time to help prepare for system installation.

The panels have the following capabilities:

Capabilities	Concord Express V4	Concord 4/Concord Commercial V4
Zones	32	96
Partitions	1	6
Bus Devices	16	16
User Codes	16	230

### Standard Panel

The following describe the basic panel (out-of-box) hardware capabilities.

- **Power:** Input for an AC step-down, plug-in style transformer.
- **Auxiliary Power Output:** Output that supplies 9 to 14 VDC with up to 1 amp for bus devices and hardwired detectors, such as smoke and motion detectors.

- **Bus A and B:** Input and output that provides communication between bus devices and the panel.
- **Siren Driver:** Output that can drive an 8-ohm load and provides intrusion and fire alarm sounds for partition 1. 6 watts max.
- **2 Onboard Outputs:** Can be used to activate other signalling devices based on system events.
  - Out 1 is a 9 to 14 VDC source output, limited to 1.0 amp max.
  - Out 2 is an open-collector output, rated up to 14 VDC, 300mA max.
- **Microphone Input:** Input used for 2-way audio when used in conjunction with the Interrogator 200 Audio Verification Module.
- **8 Supervised Hardwire Zones:** Inputs for various hardwired detectors. Zone 8 can be set up in programming to accept 2-wire smoke detectors. It sources 9 to 14 VDC, 90mA max.
- **Built-In RF Receiver:** Allows use of up to 96 or 32 319.5 MHz. crystal and/or SAW Learn Mode wireless sensors and touchpads.
- **Phone Line Connection:** Allows panel to communicate with central monitoring station and/or pagers.

**Note**

*The total current sourced from all terminals cannot exceed 1 amp.*

### **SuperBus 2000 Touchpads**

The following touchpads can be used for installer/user programming and system operation.

- **SuperBus 2000 2x16 LCD Touchpad**
- **SuperBus 2000 2x20 LCD Touchpad**
- **SuperBus 2000 2x20 VFD Touchpad**
- **SuperBus 2000 ATP 1000 Touchpad**
- **SuperBus 2000 ATP 2100 Touchpad**
- **SuperBus 2000 ATP 2600 Touchpad**
- **SuperBus 2000 GTS 50**

The following touchpads can be used only for installer quick programming, system operation and user programming.

- **SuperBus 2000 Fixed Display Touchpad**

### **SuperBus 2000 RF Transceiver**

The transceiver can be used to receive signals from sensors and touchpad that may be on the fringe of panel reception. The transceiver is compatible with all 319.5 MHz. crystal and SAW Learn Mode wireless sensors and touchpads.

### **SuperBus 2000 RF Receiver**

The receiver can be used to receive signals from sensors and touchpad that may be on the fringe of panel reception. The receiver is compatible with all 319.5 MHz. crystal and SAW Learn Mode wireless sensors and touchpads.

**Note**

*If installing this module, the Antenna Tamper feature must be turned off.*

### **Power Line Carrier Transformer**

Using this transformer allows the use of X10 Powerhouse Lamp Modules for light control and light activation during alarms.

### **SuperBus 2000 Voice Only Module**

This module provides an output for a speaker that sounds system status and alarm voice messages.

### **SuperBus 2000 Phone Interface/Voice Module**

This module allows system access and control using touch-tone telephones, on- or off-site. The module includes an output for a speaker that sounds system status and alarm voice messages.

## **SnapCards**

The following SnapCards expand the system as described:

- **8Z Input SnapCard:** Provides eight additional hardwire zone inputs, of which two are dedicated for using two wire smoke detectors.
- **4 Output SnapCard:** Provides four form C relay outputs that can be set up to activate other signalling devices, based on system events, schedules, or direct control.
- **4Z Input/2 Output Combo SnapCard:** Provides three hardwire zone inputs, one two wire smoke detector loop, and two outputs that can be set up to activate other signalling devices, based on system events, schedules, or direct control.

## **SuperBus 2000 8Z Input Module (HIM)**

Provides eight additional hardwire zone inputs.

## **SuperBus 2000 4-Relay Output Module (HOM)**

Provides four form C relay outputs that can be set up to activate other signalling devices, based on system events.

## **Interrogator 200 Audio Verification Module**

Adding this module allows central station operators to listen-in and talk to occupants on the premises to verify the emergency when an alarm report is received.

## **SuperBus 2000 Cellular Backup Module**

Provides central station communication (cellular transmission) as a backup to regular phone line(s).

## **SuperBus 2000 Energy Saver Module (ESM)**

Provides a money-saving and convenient way to monitor and control temperatures. The ESM uses low- and high-temperature limits to save energy by overriding the existing HVAC thermostat.

## **SuperBus 2000 Automation Module**

Provides a connection to a compatible home automation device.

## **SuperBus 2000 Wireless Gateway-Ready Kit**

Allows users to control and monitor the status of their system from the alarm.com internet website. Adding a modem to the module provides the link to a wireless 2-way paging network for website access.

## **SuperBus 2000 2 Amp Power Supply**

Provides an additional 12 VDC, 2 amps for powering system devices and is supervised via the panel data bus.

---

## **Installing the System**

This section describes how to install the system control panel. Before starting the installation, plan your system layout and programming using the worksheets provided in Appendix A.

Installing the system consists of the following:

- Determining the Panel Location
- Determining Total System Power and Wire Length Guidelines
- Mounting the Panel
- Identifying Panel Main Components
- Installing Optional SnapCards
- Connecting Detection Devices to Panel Zone Inputs
- Connecting Speakers
- Connecting Piezo Sirens
- Connecting an Interrogator 200 Audio Verification Module
- Connecting Alphanumeric and Fixed Display Touchpads

- Installing SuperBus 2000 Modules
- Installing an RJ-31X Phone Jack
- Connecting the Phone Line to the Panel with a DB-8 Cord
- Connecting the AC Power Transformer
- Powering Up the Panel

**Note**

(A) Class 2, Class 3, and power-limited fire alarm circuits must be installed using FPL, FPLR, FPLP, or substitute cable permitted by the National Electrical Code ANSI/NFPA 70. Wire that extends beyond the cable jacket must be separated from all other conductors by a minimum of 1/4-inch or by a nonconductive barrier.

OR

(B) Class 2, Class 3, and power-limited fire alarm circuit conductors must be installed as Class 1 or higher circuits.

**Determine the Panel Location**

Before permanently mounting the panel, determine panel location using the following guidelines:

- Centrally locate the panel with relation to detection devices whenever possible, to help reduce wire run lengths and labor.
- Locate the panel where the temperature will not exceed 120°F (49°C) or fall below 32°F (0°C).
- Avoid running wires parallel with electrical wiring or fixtures such as fluorescent lighting, to prevent wire runs from picking up electrical noise.
- Mount the panel at a comfortable working height (about 45 to 55 inches from the floor to the bottom of the panel, as shown in Figure 1).

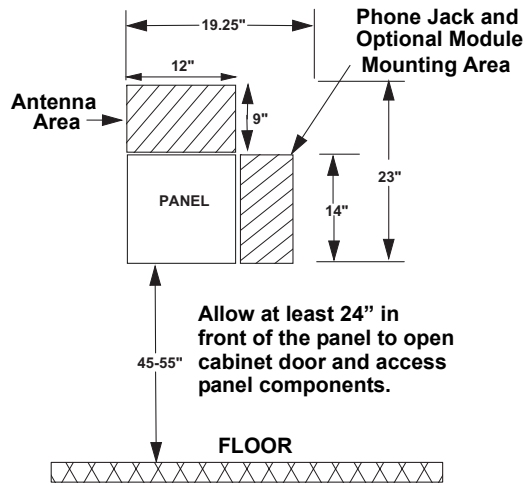

Figure 1. Determining Panel Location

- Leave space to the left and right of the panel for wiring, phone jack, and mounting optional modules.
- Allow at least 9 inches above the panel cabinet for antennas.
- Allow at least 24 inches in front of the panel to open the panel door.

**Total System Power and Wire Length Guidelines**

**Power**

The panel can supply up to 1 amp (1,000 mA) in full load alarm condition for system devices connected to panel terminals 4 (+12V), 7 and 8 (speaker terminals), 9 (OUT1), 11 (+12V), 24 (2W SMK ZONE 8), and SnapCard terminals.

For 24-hour backup, the total standby current draw for all devices connected to panel terminals 4 (+12V), 9 (OUT1), 11 (+12V), 24 (if configured for 2-wire smoke loop), and SnapCard terminals is limited to 90 mA (during normal standby condition) using a 4.5 Ah battery, or 190 mA (during normal standby condition) using a 7.0 Ah battery.

**Wire Length**

The total system wire length allowed can vary depending on devices powered by the panel, the wire length between devices and the panel, and the combined wire length of all devices.

Table 1 describes the maximum wire length allowed between compatible devices and the panel, and the minimum and maximum current draw of each device.

**Table 1: Maximum Device Wire Length and Min./Max. Current Draw**

Device	Max. Wire Length to Panel	Standby mA Draw	Alarm mA Draw
SuperBus 2000 2x16 LCD Alphanumeric Touchpad	22 ga.—300 ft. 18 ga.—750 ft.	15 mA	90 mA
SuperBus 2000 ATP 1000 Alphanumeric Touchpad	22 ga.—300 ft. 18 ga.—750 ft.	12 mA	110 mA
SuperBus 2000 ATP 2100 Alphanumeric Touchpad	22 ga.—300 ft. 18 ga.—750 ft.	30 mA	165 mA
SuperBus 2000 ATP 2600 Alphanumeric Touchpad	22 ga.—300 ft. 18 ga.—750 ft.	30 mA	165 mA
SuperBus 2000 GTS 50	22 ga.—100 ft. 18 ga.—250 ft.	270 mA	300 mA
SuperBus 2000 Fixed Display Touchpad	22 ga.—300 ft. 18 ga.—700 ft.	11 mA	65 mA
SuperBus 2000 RF Transceiver	22 ga.—1,000 ft. 18 ga.—2,500 ft.	45 mA	55 mA
SuperBus 2000 RF Receiver (see note)	22 ga.—1,100 ft. 18 ga.—2,800 ft.	35 mA	35 mA
SuperBus 2000 Phone Interface/Voice Module	22 ga.—40 ft. 18 ga.—120 ft.	25 mA	600 mA
SuperBus 2000 Voice Only Module	22 ga.—40 ft. 18 ga.—120 ft.	20 mA	300 mA (jumper) 600 mA (no jumper)
SuperBus 2000 2 Amp Power Supply		no load	no load
4 Input/2 Output SnapCard	N/A	20 mA	185 mA*
8Z Hardwire Zone Expander SnapCard	N/A	38 mA	230 mA*
4 Output SnapCard	N/A	1 mA	130 mA*
SuperBus 2000 8Z Input Module	22 ga.—1,800 ft. 18 ga.—4,000 ft.	18 mA	35 mA
SuperBus 2000 4-Relay Output Module	22 ga.—350 ft. 18 ga.—900 ft.	12 mA	180 mA
SuperBus 2000 Energy Saver Module	22 ga.—1,600 ft. 18 ga.—4,000 ft.	20 mA	20 mA
SuperBus 2000 Cellular Backup Module	Standard Power: 22 ga.—15 ft. 18 ga.—40 ft.	90 mA	1600 mA
	High Power 22 ga.—10 ft. 18 ga.—30 ft.	90 mA	1900 mA
SuperBus 2000 Automation Module	22 ga.—1,500 ft. 18 ga.—4,000 ft.	30 mA	35 mA
SuperBus 2000 Wireless Gateway-Ready Kit	22 ga.—40 ft. 18 ga.—90 ft.	65 mA	1600 mA
Interrogator 200	22 ga.—3,200 ft. 18 ga.—4,500 ft.	10 mA	10 mA
Interrogator AVM	22 ga.—110 ft. 18 ga.—260 ft.	45 mA	300 mA
2-Wire Smoke Detectors (ESL 429AT, 521B, 521BXT)	22 ga.—330 ft. 18 ga.—330 ft.	70 $\mu$ A	60 mA
2-Wire Smoke Detectors (System Sensor 2400, 2400TH)	22 ga.—330 ft. 18 ga.—330 ft.	120 $\mu$ A	80 mA
Hardwire Interior Siren (13-949)	22 ga.—750 ft. 18 ga.—1,500 ft.	0 mA	85 mA
Piezo Dynamic Exterior Siren (13-950)	22 ga.—750 ft. 18 ga.—1,500 ft.	0 mA	150 mA

**Table 1: Maximum Device Wire Length and Min./Max. Current Draw (Continued)**

Device	Max. Wire Length to Panel	Standby mA Draw	Alarm mA Draw
Speaker Siren (60-528 or 13-060)	18 ga.—100 ft.	0 mA	500 mA
*Maximum current draw for the SnapCards does not include the load which may be applied to their auxiliary DC supply.			

**Note**

When installing SuperBus 2000 RF Receiver Modules, the Antenna Tamper feature must be set to off (see REPORTING—GLOBAL in the “Programming” section).

Table 2 describes the total system wire lengths allowed for all SuperBus 2000 devices when installing systems using unshielded or shielded cable. (The maximum wire length for individual devices is shown in Table 1)

**Table 2: Total System Wire Length Allowed**

Wire Type	Total System Wire
18-gauge, unshielded	4,000 ft.
18-gauge, shielded	3,000 ft.
22-gauge, unshielded	4,000 ft.
22-gauge, shielded	3,000 ft.

After determining panel location, run all necessary wires to that location using the guidelines in Table 3.

**Table 3: Wire Requirements**

Device	Wire Requirements
AC Power Transformer	2-conductor, 18-gauge, 25 feet max
Earth Ground	Single conductor, 16-gauge solid, 25 feet max
Telephone (RJ-31X)	4-conductor
Detection Devices	2- or 4-conductor, 22-gauge, 1,000 feet max 2- or 4-conductor, 18-gauge, 2,500 feet max (based on 30 ohms max loop resistance including device)
Speakers	2-conductor, 18-gauge, 100 feet max
SuperBus 2000 Devices	4-conductor, 22- or 18-gauge (see Table 1)
Interrogator 200 AVM Power and Microphone	4-conductor, 22-gauge, shielded (see Table 1)
2-Wire Smoke Detectors	2-conductor, 22-gauge, 330 feet max 2-conductor, 18-gauge, 830 feet max (based on 10-ohms max loop resistance plus a 2k-ohm, end-of-line resistor)

**Mounting the Panel**

Use the following procedure to mount the panel to the wall or wall studs.



**Caution**

Make sure you are free of static electricity whenever you work on the panel with the cover open. To discharge any static, first touch the metal panel chassis, then stay in contact with the chassis when touching the circuit board. Using an approved grounding strap is recommended.

➤ **To mount the panel (see Figure 2):**

1. Remove the panel door and remove the necessary wiring knockouts. Be careful not to damage the circuit board.
2. Feed all wires through wiring knockouts and place the panel in position against the wall.
3. Level the panel and mark the top and bottom mounting holes.
4. Install anchors where studs are not present.
5. Partially insert screws into the two top mounting hole locations, then hang the panel on the two screws.

- Recheck for level, insert the two lower screws, and tighten all four mounting screws.

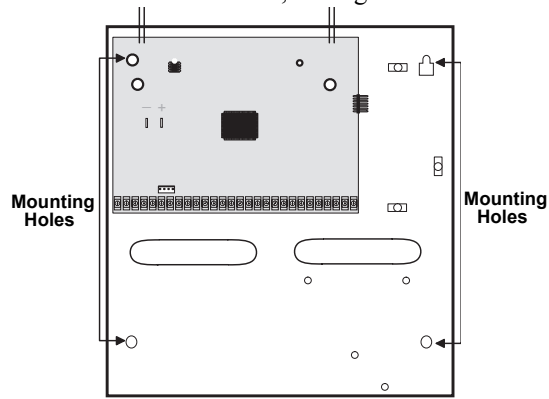

Figure 2. Mounting the Panel

## Identify Panel Components

Before installing devices and making wiring connections, familiarize yourself with the main panel components. Figure 3 shows the main component locations.

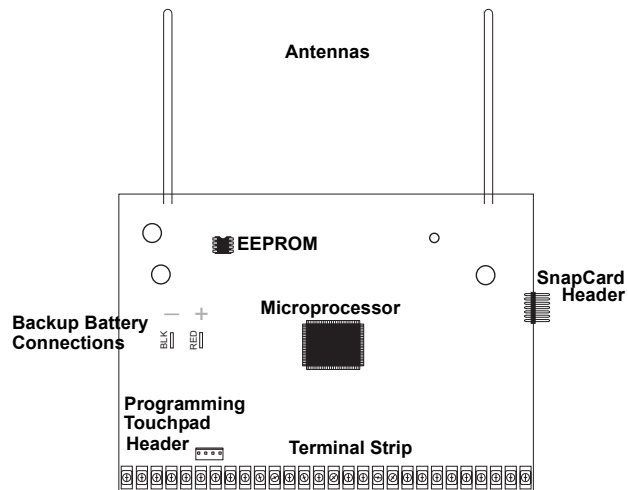

Figure 3. Circuit Board Main Components

## Installing Antenna Shrouds

**Note**  
Skip this step for Concord 4 Hybrid and Concord 4 commercial systems.

Install a plastic antenna shroud (included with panel) over each antenna and snap them into the holes on top of the enclosure (see Figure 4).

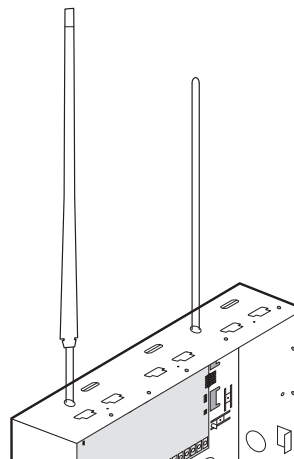

Figure 4. Installing Antenna Shrouds

**Note**

For best results, it is recommended that you crimp a spade lug on the wire end at the panel and secure the lug to the enclosure as shown in Figure 5.

### Connecting the Panel to Earth Ground

For maximum protection from lightning strikes and transients, connect the enclosure to earth ground as shown in Figure 5. Use 16-gauge, solid copper wire from an earth grounded cold water pipe clamp to the enclosure.

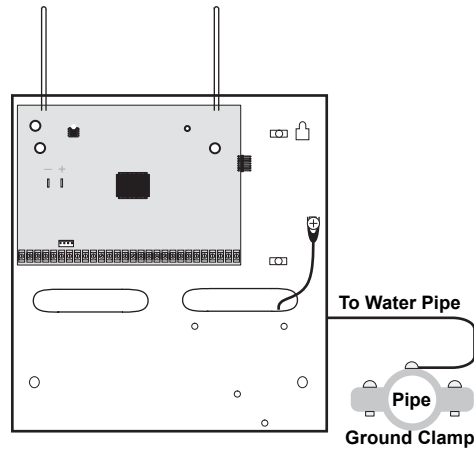

Figure 5. Connecting the Panel to Earth Ground

### Installing Optional SnapCards

The SnapCard Header on the right side of the panel allows for the installation of one SnapCard. Install the desired SnapCard onto the panel SnapCard Header and secure it in place with two screws, included with the card (see Figure 6).

Connect all necessary input/output wiring using the *Installation Instructions* included with the card.

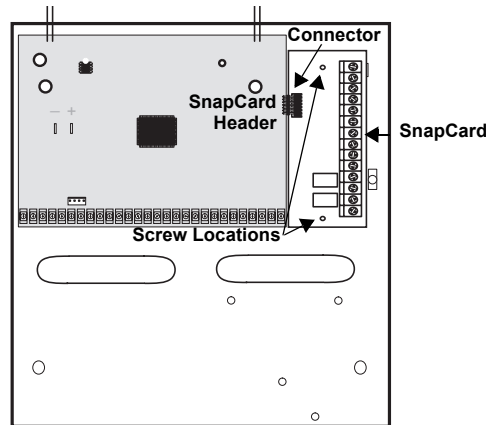

Figure 6. Installing a SnapCard

**Note**

The panel comes with factory programmed onboard hardwire zones. Install 2k-ohm, end of line (EOL) resistors on all unused factory programmed onboard hardwire zones. If you don't want to install EOL resistors, delete any unused zones from memory. See Table 7 for onboard hardwire zone factory programming.

### Connecting Detection Devices to Panel Zone Inputs

Zone inputs 1 through 8 are supervised using included 2k-ohm, end-of-line resistors at the last device on each circuit. All eight zones accept either normally open (N/O) or normally closed (N/C) detection devices.

### Connecting Intrusion Detection Devices

Figure 7 shows the typical wiring for N/C and N/O door/window intrusion detection and the typical wiring for a Detection Systems model DS922 (part no. 13-082) motion detector. The minimum available panel voltage for hardwired PIR motion detectors is 8.5 VDC (9.5 VDC for UL listed installations).

**Note**

When using 2-wire smoke detectors on zone 8, the Two-Wire Smoke setting (in program mode) must be turned on **before** entering the LEARN SENSORS menu. See ONBOARD OPTIONS—INPUTS in the section "Programming the Panel" for complete details.



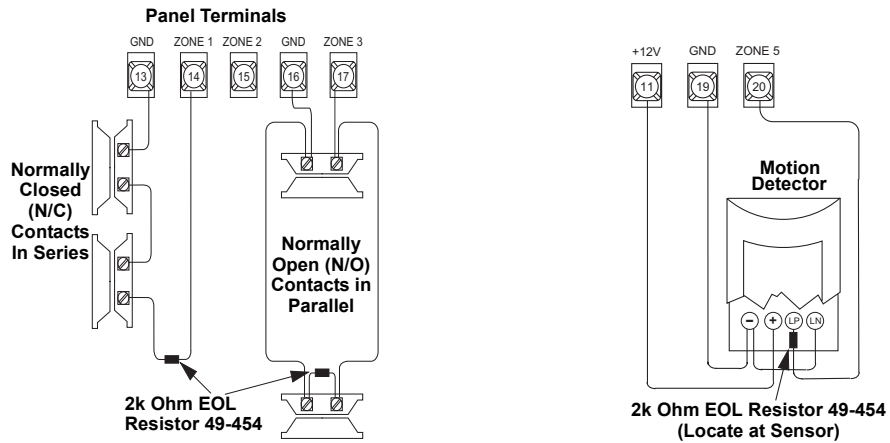

Figure 7. Connecting N/C and N/O Intrusion Detection and Motion Detector Circuits to the Panel

### Connecting 2-Wire Smoke Detectors

Zone input 8 can be set up (in program mode) to accept the following 12 VDC, 2-wire smoke detectors:

- System Sensor models 2400, 2400TH
- ESL models 429AT, 521B, 521BXT—(models 521B and 521BXT require the following dip switch settings: 1-on, 2-off)



**Caution** Use only the 2-wire smoke detector models described above. Alarm signals from other detectors may not be processed correctly if the panel has lost AC power and is operating only from the backup battery.

When set up for 2-wire smoke detectors, zone 8 can handle up to 20 smoke detectors (all of the same model, as listed above) with 120 uA maximum idle current per detector. Maximum total loop current allowed in an alarm condition is 90 mA. Connect one or more, 2-wire smoke detectors to the panel as shown in Figure 8.

**Note**  
The Two-Wire Smoke setting (in program mode) must be on when using 4-wire smoke detectors as shown in Figure 8. See ONBOARD OPTIONS—INPUTS in the section “Programming the Panel” for complete details.

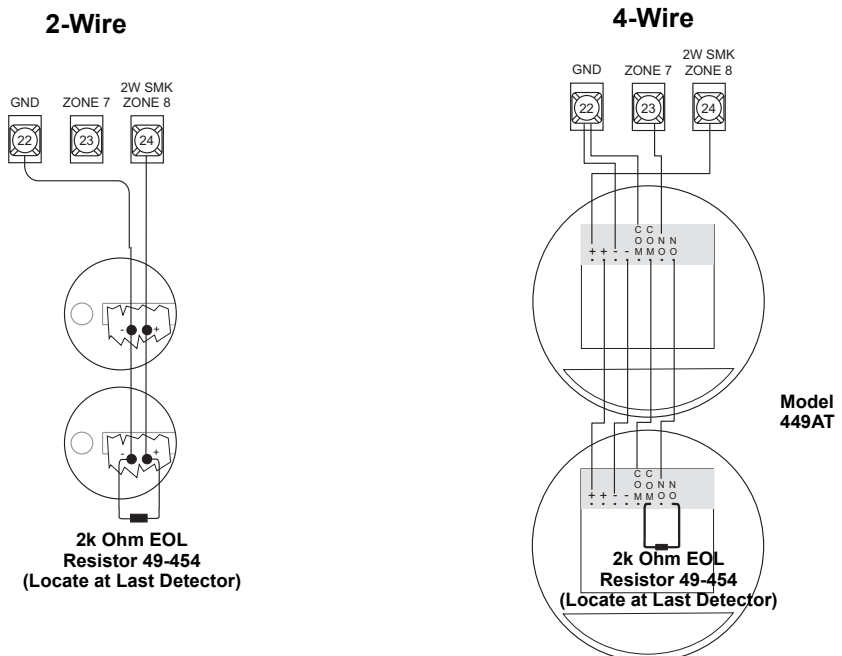

Figure 8. Connecting 2 and 4-Wire Smoke Detectors to the Panel

## Connecting 4-Wire Smoke Detectors

Zone input 8 can be used with 4-wire smoke detectors that latch and remain in the alarm state until power is removed, then restored to the detector. The panel provides this power interruption from terminal 24 (2W SMK ZONE 8) only when zone 8 is learned into sensor group 26 (fire) and the Two-Wire Smoke option is on.

**Note**  
Zone 8 must be learned into sensor group 26 (fire) and the 2-Wire Smoke feature must be on for connected smoke detectors to reset after canceling a fire alarm.

Table 4 describes the minimum available panel power. Use only 4-wire smoke detectors that operate at these power limits. Connect up to five Sentrol (ESL) model 449AT (part no. 13-360) smoke detectors to panel power and zone 8 input as shown in Figure 8.

**Table 4: Panel Minimum Available Power**

Min. Voltage/Max. Current Available
8.3 VDC, up to 30 mA total (combined alarm) current
8.1 VDC, up to 40 mA total (combined alarm) current
7.6 VDC, up to 60 mA total (combined alarm) current
7.1 VDC, up to 80 mA total (combined alarm) current

## Connecting Speakers

**Note**  
Install all sirens/speakers indoors, in a concealed location.

The panel provides one siren driver output for intrusion (steady), fire (temporal 3), and auxiliary (on-off-on-off) alarm sounds. This output trips only for partition 1 alarms.

The output can drive a single 8-ohm speaker or multiple speaker circuit of 8-ohms or higher (as shown in the following speaker wiring diagrams). Compatible speakers are described below.



To avoid disabling the panel speaker output, do not make speaker connections with the panel powered up.

### Caution 15-Watt Speaker (13-060)

**Note**  
Do not connect a bell or piezo siren to the speaker output (terminals 7 and 8).

For exterior siren applications, connect the speaker to the panel using 18-gauge wire as shown in Figure 9.

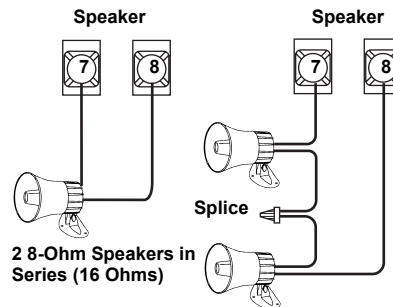

**Figure 9. Connecting Exterior Speakers to the Panel**

## Hardwire Interior Speaker (60-528)

Connect interior speakers to the panel using 18-gauge wire as shown in Figure 10.



**Caution**

Connect only the large speaker to the panel terminals 7 and 8 as shown. The smaller speaker cannot handle the output of terminals 7 and 8. To avoid damaging the speaker, the smaller speaker should not be connected to terminals 7 and 8.

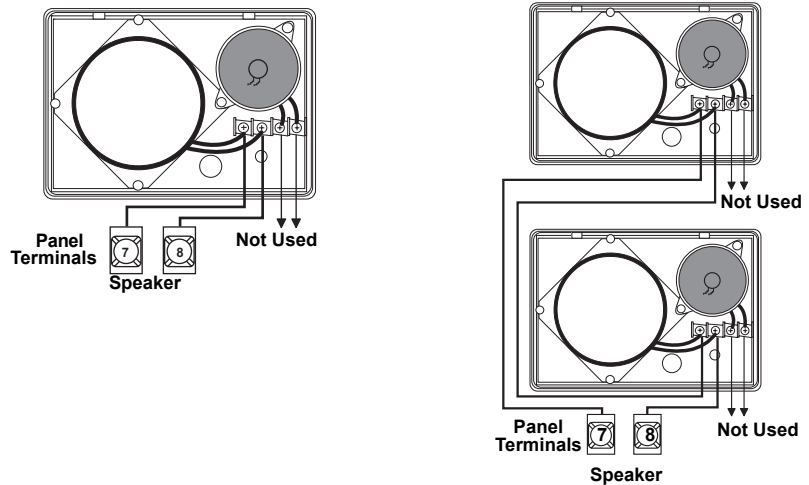

Figure 10. Connecting Hardwire Interior Speakers

## Connecting Exterior/Interior Piezo Sirens

### Output 1

**Note**  
For 24-hour backup, external power drain is limited to 90 mA (during normal standby condition), using a 4.5 Ah battery, or 190 mA continuous using a 7.0 Ah battery.

Onboard output 1 (OUT 1—terminal 9) is a 9 to 14 VDC switched, programmable output that can handle a maximum of 1,000 mA current. The default setting (01614) activates the output 30 seconds after a police or fire alarm condition occurs. This allows you to connect a piezo siren without changing the output configuration number in programming. This output is typically used for exterior siren applications. (For more information on output configuration numbers, see “Onboard Options Menu”.)

### Piezo Dynamic Exterior Siren (13-950)

**Note**  
This siren is not UL approved for use as an outdoor sounding device.

Connect the siren to panel as shown in Figure 11.

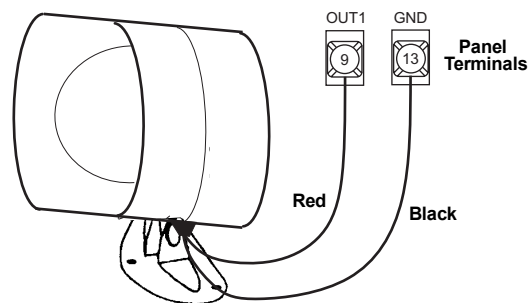

Figure 11. Connecting Exterior Sirens

## Output 2

Onboard output 2 (OUT 2—terminal 10) is an open-collector (switched path-to-ground), programmable output that can handle a maximum of 300 mA current sink and up to 14 VDC. The default setting (01710) activates the output for status and alarm tones, allowing for a piezo siren connection without changing the output configuration number. This output is typically used for interior siren applications. (For more information on output configuration numbers, see “Onboard Options Menu”.)

### Hardwire Interior Siren (13-949)

This siren has two inputs; steady (#1) and warble (#2). Use the steady (#1) terminal for Concord 4 panels. The siren also includes a cover tamper switch that can be connected to a hardwire zone input on the panel, SnapCard or SuperBus 2000 Hardwire Input Module. Connect the siren to the panel/zone input terminals as shown in Figure 12.

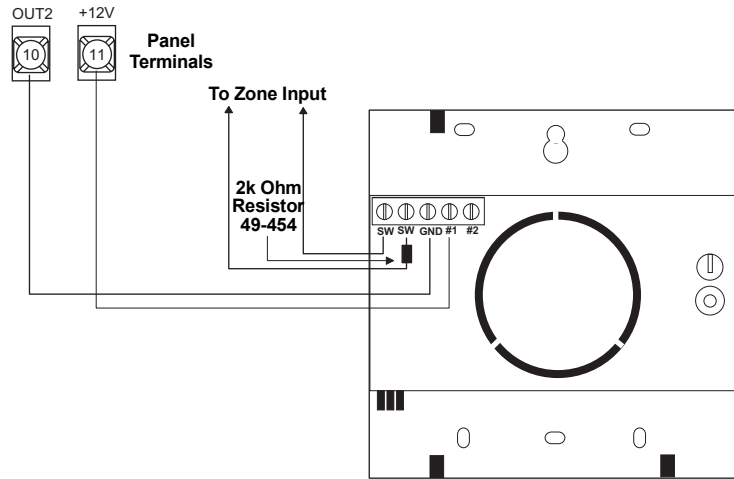

Figure 12. Connecting Exterior and Interior Sirens

### Connecting an Interrogator 200 Audio Verification Module (60-677)

Connect the Interrogator 200 Audio Verification Module (AVM) to the panel terminals as shown in Figure 13. Partition 1 use only.



Caution

If a speaker is already connected to panel terminals 7 and 8, the Interrogator 200 speaker must be hooked up in series with that speaker to provide a 16-ohm load. Hooking up speakers in parallel to panel terminals 7 and 8 creates a 4-ohm load that can cause permanent damage to the panel.

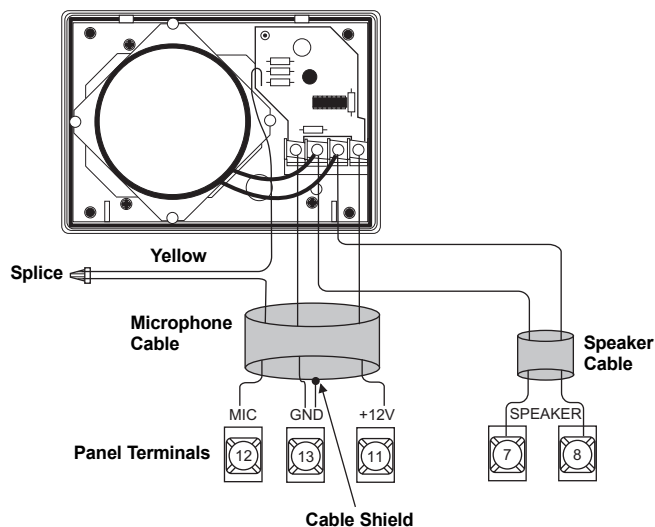

Figure 13. Connecting an Interrogator 200 AVM

## Connecting SuperBus 2000 Touchpads

SuperBus 2000 touchpads may have wires or screw terminals. All use the same wiring scheme for power and bus connections. Connect touchpads to the as shown in Figure 14.

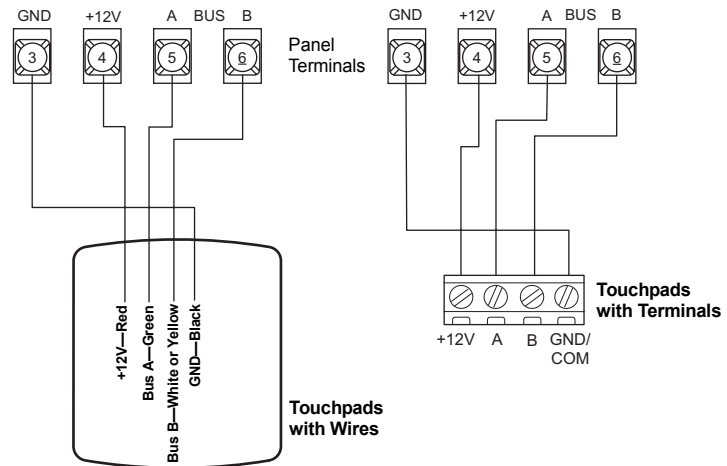

Figure 14. Connecting Touchpads to the Panel

## Installing SuperBus 2000 Modules

SuperBus 2000 modules can be installed inside the panel cabinet or away from the panel with their included enclosure.

### Mounting Modules Inside the Panel Enclosure

Use the following guidelines when mounting modules inside the panel enclosure (see Figure 15):

- Up to 4 of the SuperBus 2000 modules listed in Table 1 can be mounted inside the cabinet.
- The 2 Amp Power Supply and Phone Interface/Voice Module each use two mounting spaces when mounted inside the panel enclosure.
- The panel includes two support standoffs you install to secure module backplates to the panel.
- Install the standoffs at the locations shown.
- The cabinet has built-in mounting clips on the top and sides that module backplates slide onto for mounting.

#### Note

Even if you don't plan to mount modules inside the cabinet, install the support standoffs for future use and to avoid losing them.

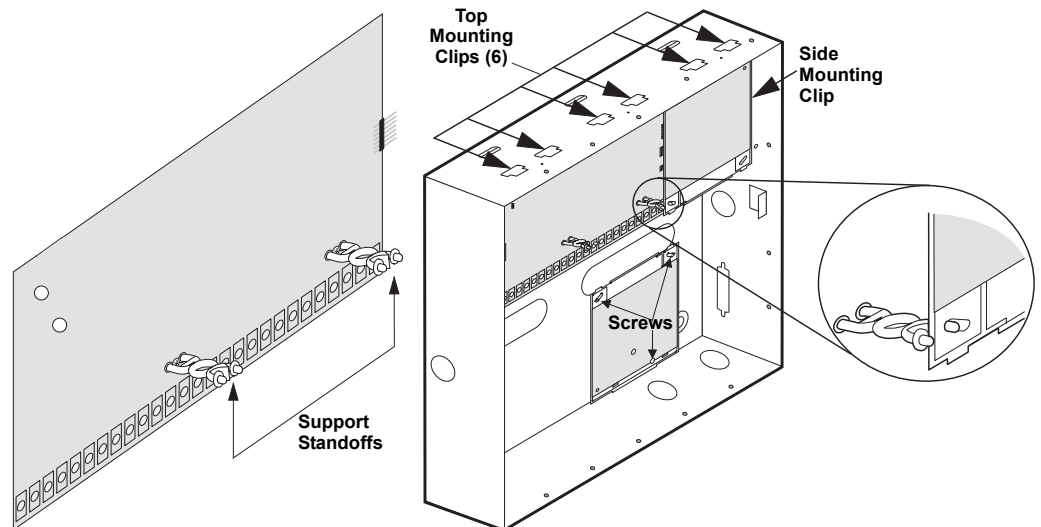

Figure 15. Installing SuperBus 2000 Modules

## SuperBus 2000 2 Amp Power Supply (600-1019)

Refer to power supply installation instructions for the mounting procedure.

Connect the power supply to the panel terminals and devices to be powered as shown in Figure 16.

### Note

Do not connect power (AC and battery) to the power supply until the panel is ready for power up. For power supply AC and battery connections, see the SuperBus 2000 2 Amp Power Supply Installation Instructions.

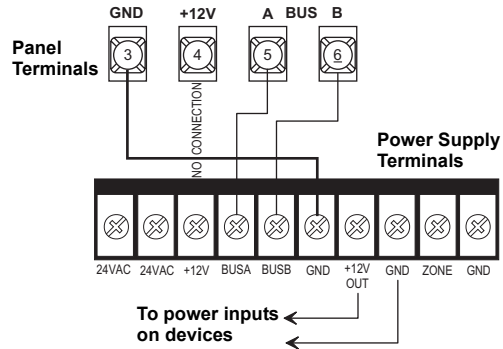

Figure 16. Wiring the SuperBus 2 Amp Power Supply to the Panel

## SuperBus 2000 Transceiver Module (600-1025-01-95R) and SuperBus 2000 RF Receiver Module (60-764-95R-01)

The transceiver and receiver expand RF reception range when placed in the vicinity of sensors on the fringe of panel RF reception.

Refer to transceiver or receiver installation instructions for the mounting procedure.

Connect the transceiver and receiver (up to four total) to the panel as shown in Figure 17.

### Note

When installing SuperBus 2000 RF Receiver Modules, the Antenna Tamper feature must be set to off (see REPORTING—GLOBAL in the "Programming" section).

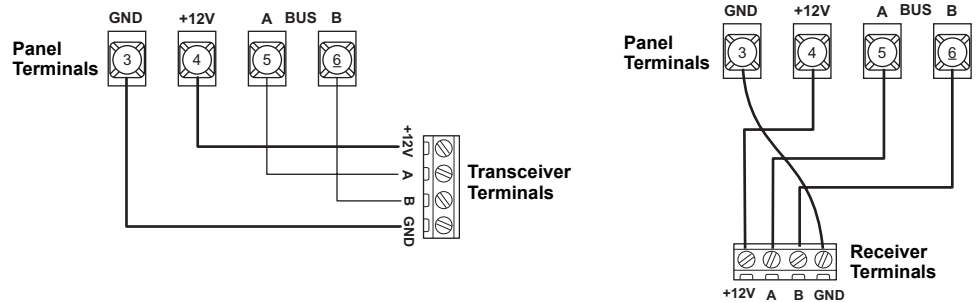

Figure 17. Wiring the SuperBus 2000 RF Transceiver and RF Receiver to the Panel

## SuperBus 2000 Voice Only Module

The module can be mounted inside or outside of the control panel cabinet. Refer to the SuperBus 2000 Voice Only Module Installation Instructions included with each module, for complete mounting instructions.

**Note**  
In UL Listed installations, the Voice Only Module is for supplementary use only.

The module requires panel power and bus connections, and speaker connection through panel terminals as shown in Figure 18.

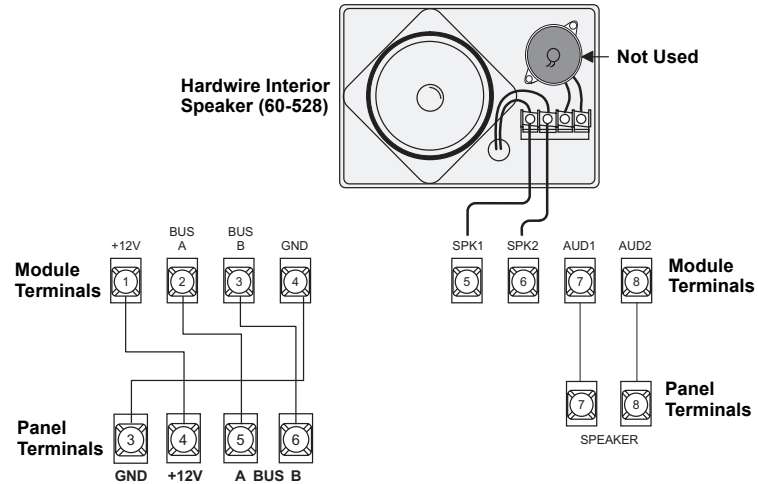

Figure 18. Wiring for the Voice Only Module

**Note**  
For RJ-31X connections, see "Installing an RJ-31X Phone Jack (13-081)."

### SuperBus 2000 Phone Interface/Voice Module (60-777-01)

The Phone Interface/Voice Module includes two backplates for mounting the module inside the control panel cabinet. The module can also be mounted outside of the control panel using an optional plastic housing (part no. 60-800). Refer to the *SuperBus 2000 Phone Interface/Voice Module Installation Instructions* included with each module, for complete mounting instructions.

**Note**  
In UL Listed installations, the Phone Interface/Voice Module is for supplementary use only.

The module requires panel power and bus connections, phone line connection through panel terminals and DB-8 cord (from an RJ-31X jack), and speaker connection through panel terminals. Connect the module to the panel power and bus terminals as shown in Figure 19.

For partition 1, connect the phone line to the module through the panel terminals and DB-8 cord (from an RJ-31X jack) as shown in Figure 19. For partitions 2-6 phone connections, see the SuperBus 2000 Phone Interface/Voice Module Installation Instructions.

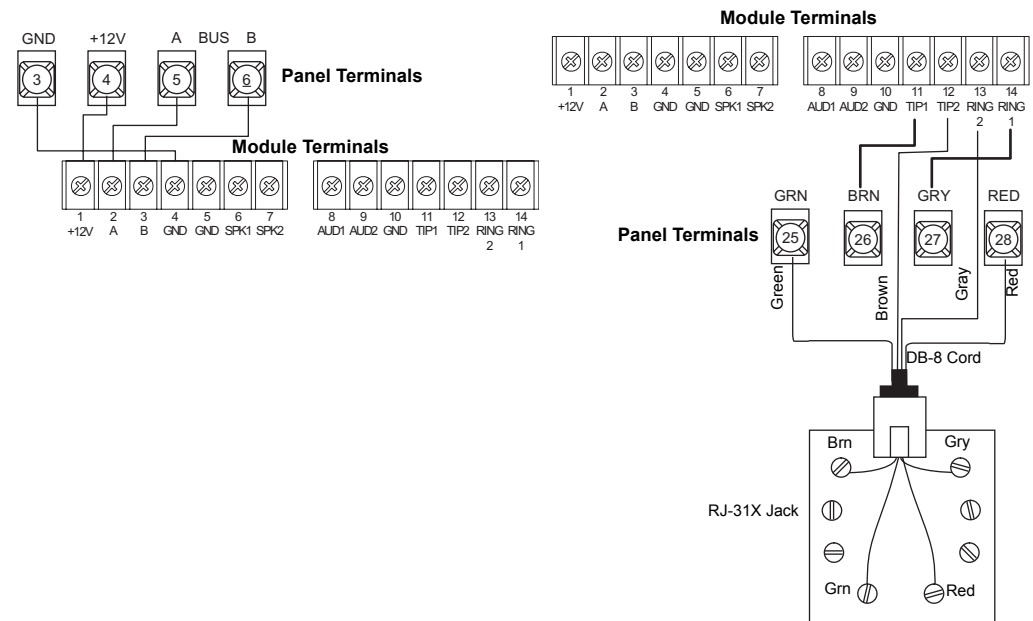

Figure 19. Wiring for the Phone Interface/Voice Module

**Note**  
To prevent status voice messages from being broadcast outside, do not connect exterior speakers to Phone Interface/Voice module terminals 6 and 7.

### Wiring for Status Voice Messages Only

Connect an interior speaker to the Phone Interface/Voice Module terminals as shown under "Status" in Figure 20. When connected as shown, the speaker only produces status voice messages. In an alarm, the speaker announces voice status messages.

### Wiring for Status and Alarm Messages

Make the connection shown under “Status and Alarm” in Figure 20 only if the Phone Interface/Voice Module is being installed in Partition 1 and alarm sounds are desired. In an alarm, the speaker alternates between alarm siren tones and voice status messages.

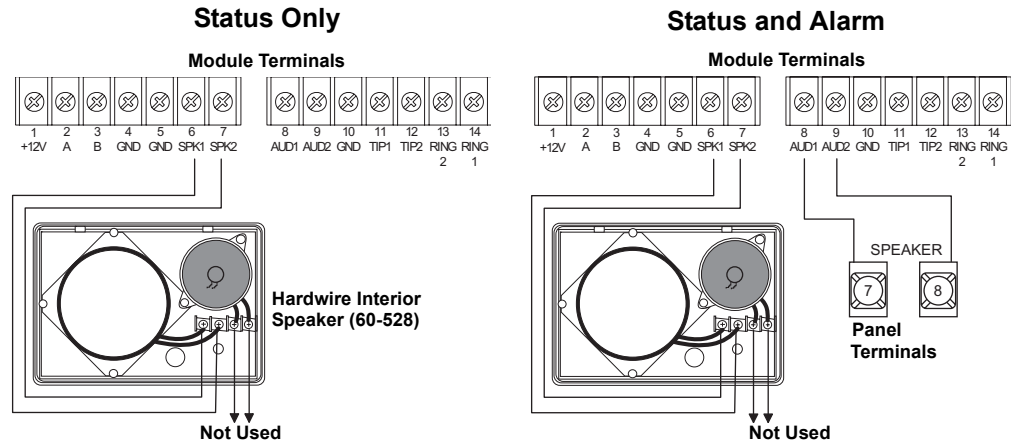

Figure 20. Wiring the Phone Interface/Voice Module for Status Only or Status and Alarm Messages

### SuperBus 2000 Energy Saver Module (60-620-01)

Connect the Energy Saver Module to the panel and premises thermostat as shown in Figure 21.

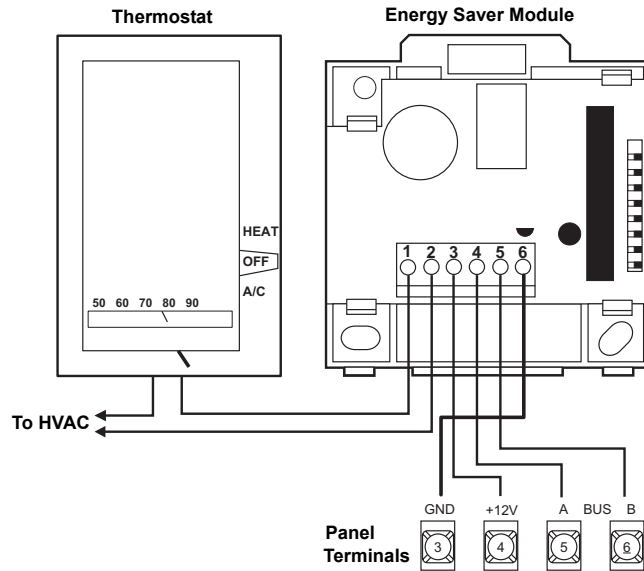

Figure 21. Wiring the Energy Saver Module to the Panel

### SuperBus 2000 8Z Input Module (60-774)

Connect the SuperBus 2000 8Z Input Module to the panel as shown in Figure 22.

Connect all necessary input wiring using the *Installation Instructions* included with the module.

### SuperBus 2000 4-Relay Output Module (60-770)

Connect the SuperBus 2000 4-Relay Output Module to the panel as shown in Figure 22.



Connect all necessary output wiring using the *Installation Instructions* included with the module.

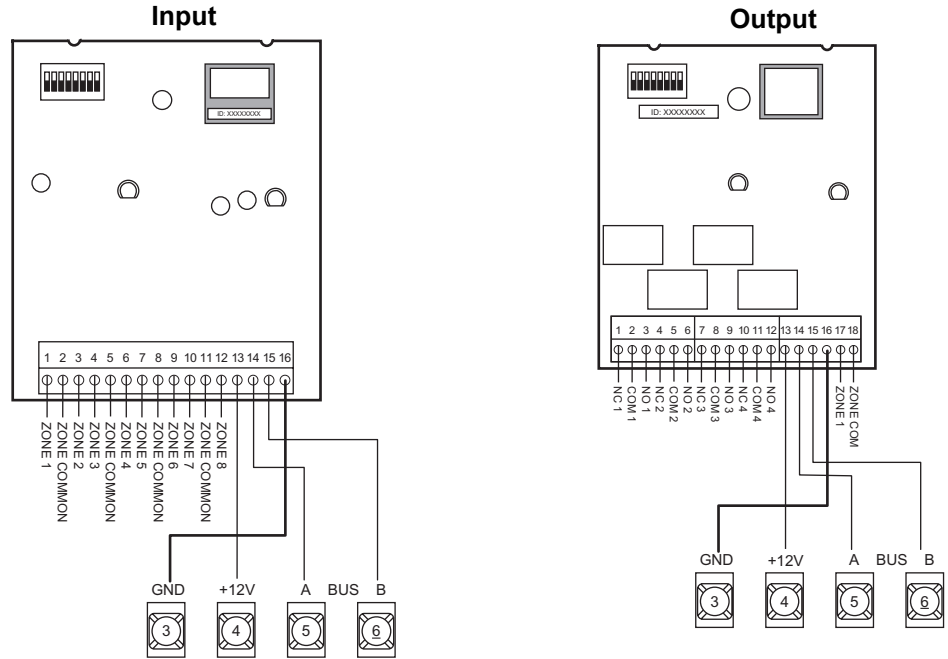

Figure 22. Wiring Input and Output Modules to the Panel

### SuperBus 2000 Cellular Backup Module

Connect the SuperBus 2000 Cellular Backup Module to the SuperBus 2000 2 Amp Power Supply and panel as shown in Figure 23.



Since the SuperBus 2000 Cellular Backup Module draws more than 1 amp, it must be powered by the SuperBus 2000 2 Amp Power Supply and not the panel.

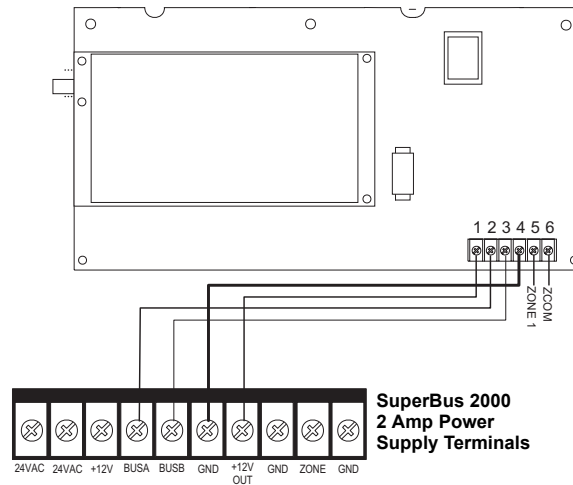

Figure 23. Wiring the Cellular Backup Module to the Panel

## SuperBus 2000 Automation Module (60-783-02)

Connect the SuperBus 2000 Automation Module to the panel as shown in Figure 24.

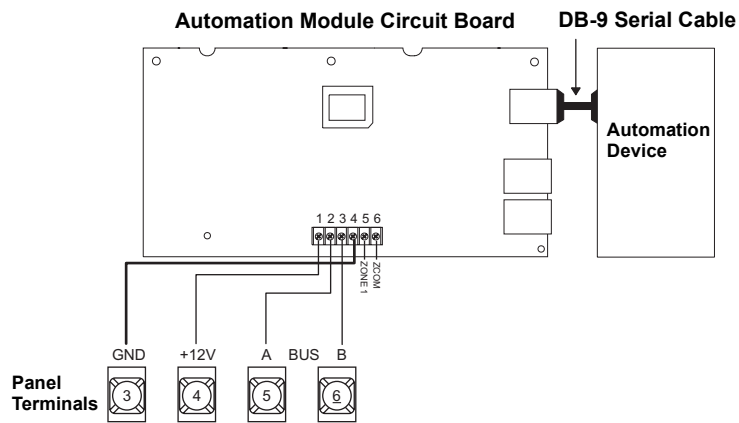

Figure 24. Connecting the SuperBus to the Panel

## SuperBus 2000 Wireless Gateway-Ready Kit (600-1010)

Connect the SuperBus 2000 Wireless Gateway Module to the SuperBus 2000 terminals as shown in Figure 25.



Caution

Since the SuperBus Wireless Gateway-Ready Kit draws more than 1 amp, it must be powered by the SuperBus 2000 2 Amp Power Supply and not the panel.

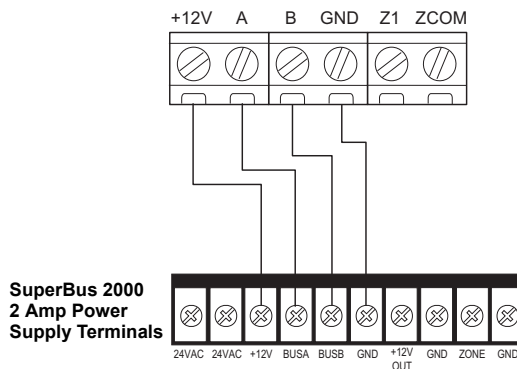

Figure 25. Connecting the Wireless Gateway Module to the Panel

### Note

The panel cannot be used on a digital or PBX phone line. These systems are designed for digital type devices only, operating anywhere from 5 volts DC and up. The panel uses an analog modem and does not have a digital converter, adapter, or interface to operate through such systems.

### Note

Connecting the panel to an analog line off the phone switch places the panel ahead of the phone system, preventing panel access from phones on the premises. However, the panel can still be accessed from off-site phones.

## Installing an RJ-31X Phone Jack (13-081)

Use the following guidelines when installing an RJ-31X phone jack for system control by phone and central station monitoring.

- Locate the RJ-31X jack (CA-38A in Canada) no further than five feet from the panel.
- The panel must be connected to a standard analog (loop-start) phone line, that provides 48 volts DC (on-hook or idle).
- For full line seizure, install an RJ-31X phone jack on the premises phone line so the panel is ahead of all phones and other devices on the line. This allows the panel to take control of the phone line when an alarm occurs, even if the phone is in use or off-hook.
- If an analog line is not available, contact a telecommunications specialist and request an analog line off the phone switch (PBX mainframe) or a 1FB (standard business line).

### ➤ To connect a phone line to the panel using an RJ-31X/CA-38A jack:

1. Run a 4-conductor cable from the TELCO protector block to the jack location (see A in Figure 26).
2. Connect one end of the cable to the jack (see B in Figure 26).
3. At the TELCO protector block, remove the premises phone lines from the block and splice them to the black and white (or yellow) wires of the 4-conductor cable (see C in Figure 26).

4. Connect the green and red wires from the 4-conductor cable to the TIP (+) and RING (-) posts on the block (see D in Figure 26).
5. Check the phones on the premises for dial tone and the ability to dial out and make phone calls. If phones do not work correctly, check all wiring and correct where necessary. Proceed to the “Troubleshooting” section of this manual if problems persist.

### Connecting the Phone Line to the Panel with a DB-8 Cord

After installing the RJ-31X jack, you are ready to connect the phone line to the panel. A DB-8 cord (not included) uses a plug at one end for connecting to the RJ-31X module and flying leads on the other end for panel terminal connections.

➤ **To connect the DB-8 cord to the panel terminals and RJ-31X jack (see Figure 26):**

1. Connect the green, brown, gray, and red flying leads from the DB-8 cord to panel terminals 25, 26, 27, and 28.
2. Insert the DB-8 cord’s plug into the RJ-31X.
3. Check the phones on the premises for dial tone and the ability to dial out and make phone calls. If phones do not work correctly, check all wiring and correct where necessary. Proceed to the “Troubleshooting” section of this manual if problems persist.

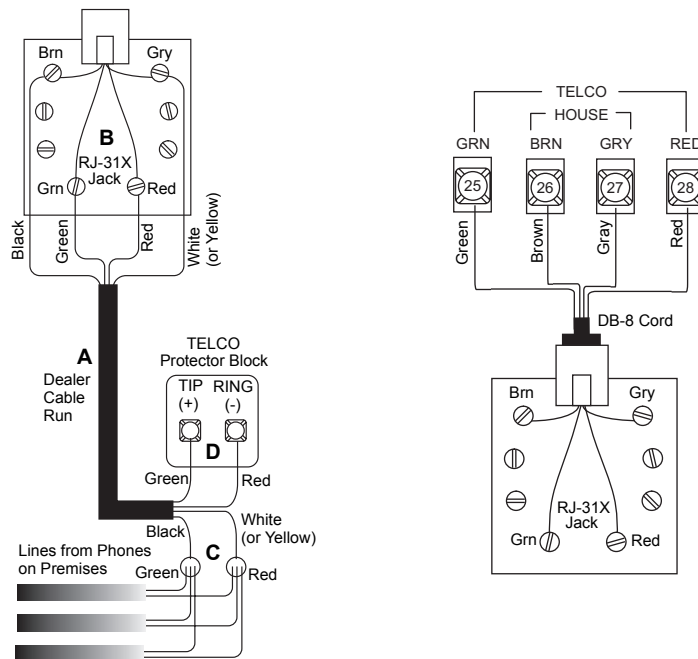

Figure 26. Wiring an RJ-31X Jack and DB-8 Cord to the Panel

### Connecting the AC Power Transformer

The panel must be powered by a plug-in stepdown transformer that supplies 16.5 VAC, 40 VA (600-1023 or 600-1023-CN).

For systems that include X10 Lamp Modules, the panel must be powered with the Line Carrier Power Transformer that supplies 16.5 VAC, 40 VA (600-1024 or 600-1024-CN). Connect the power transformer to the panel as shown in Figure 27.



**Caution**

**Do not plug in the power transformer or connect the backup battery at this time. The panel must be powered up using the sequence of steps described in the next section, “Powering Up the Panel.”**

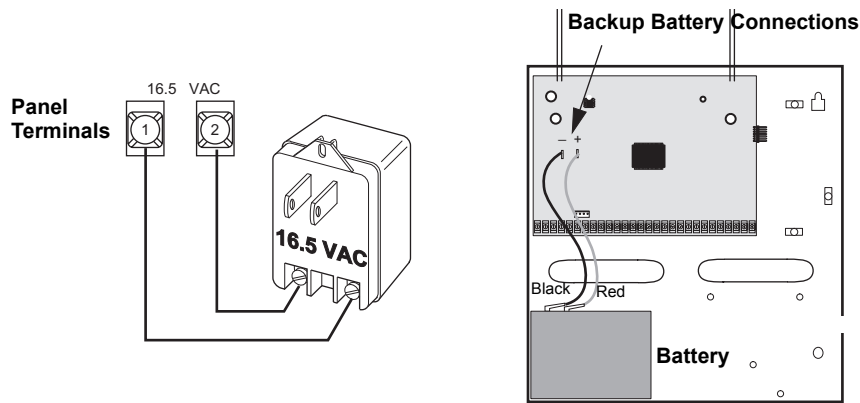

Figure 27. Connecting Panel Power Transformer and Backup Battery

## Powering Up the Panel

After connecting and wiring all devices to the panel, you are ready to apply AC and backup battery power to the panel.

### ➤ To power up the panel (see Figure 27):

1. Connect the red and black battery leads (included with panel) to the lugs on the panel.
2. Connect the other ends of the battery leads to the battery terminals.
3. Plug the transformer into an outlet that is not controlled by a switch.  
Alphanumeric touchpads display **\*\*\*\*\***, then *SCANNING BUS DEVICES*, and finally a date and time display.
4. To permanently mount the transformer, unplug it and remove the existing screw securing the AC outlet cover.



### Warning

Use extreme caution when securing the transformer to a metal outlet cover. You could receive a serious shock if a metal outlet cover drops down onto the prongs of the plug while you are securing the transformer and cover to the outlet box.

Hold the outlet cover in place and plug the transformer into the lower receptacle.

5. Use the screw supplied with the transformer to secure the transformer to the outlet cover.

### Note

If alphanumeric touchpads don't display anything, immediately unplug the transformer and disconnect the backup battery. Refer to the "Troubleshooting" section.

## Programming the Panel

For on-site system programming, an alphanumeric touchpad is required.

### Entering Program Mode

Entering program mode is done using an installer/dealer code (default = 4321). The system can be put into program mode only when all partitions are disarmed.

### ➤ To enter program mode:

1. Make sure the system is disarmed in all partitions.
2. Press 8 + 4321 + 0 + 0. The display shows *SYSTEM PROGRAMMING*.

### ➤ To enter programming mode using a programming touchpad:

1. Connect the red, black, green, and white wires from the Programming Touchpad Cable (60-791) to the power and bus wires/terminals on an alphanumeric touchpad, matching the +12V (red), Bus A (green), Bus B (white), and GND (black) on each.
2. Make sure the system is powered up and disarmed.
3. Connect the plug on the cable onto the panel programming touchpad header (see Figure 28).
4. Press 8 + 4321 + 0 + 2. The touchpad sounds one short beep. Press \* and verify that the display shows *SERVICE TOUCHPAD ACTIVE*.
5. Press 8 + 4321 + 0 + 0 and the display shows *SYSTEM PROGRAMMING*.

### Note

If the system is powered up after the programming touchpad is connected or if a bus command scan is executed, the programming touchpad will be "learned" into the system and must later be manually deleted.

- After programming is completed, simply disconnect the touchpad from the panel header.

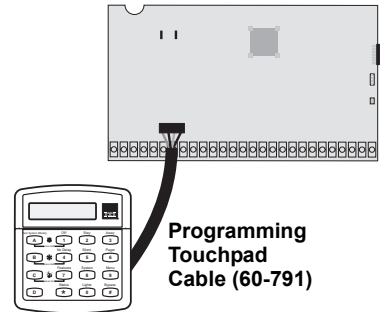

Figure 28. Connecting a Programming Touchpad

### Touchpad Button Programming Functions

In program mode, touchpad buttons let you navigate to all installer programming menus for configuring the system. Table 5 describes the touchpad button functions in program mode.

Table 5: Touchpad Button Functions

Button	Programming Function
#	Selects menu item or data entry.
*	Deselects menu item or data entry (if pressed before #).
A (▲) B (▼)	Scroll through available options at the current menu tier. Also scroll through sensor text options during sensor text programming.
C	Enters pauses when programming phone numbers.
D	Deletes certain programmed settings.
0 thru 9	Enter numeric values wherever needed.
1 & 2	Select off (1) or on (2) wherever needed.
1 thru 6	Press and hold to enter alphabetical characters A thru F for account numbers.
7 & 9	Press and hold to enter * (7) or # (9) for phone numbers.

### Moving Through Program Mode Tiers and Menus

There are two basic tiers of programming menus (see Figure 29).

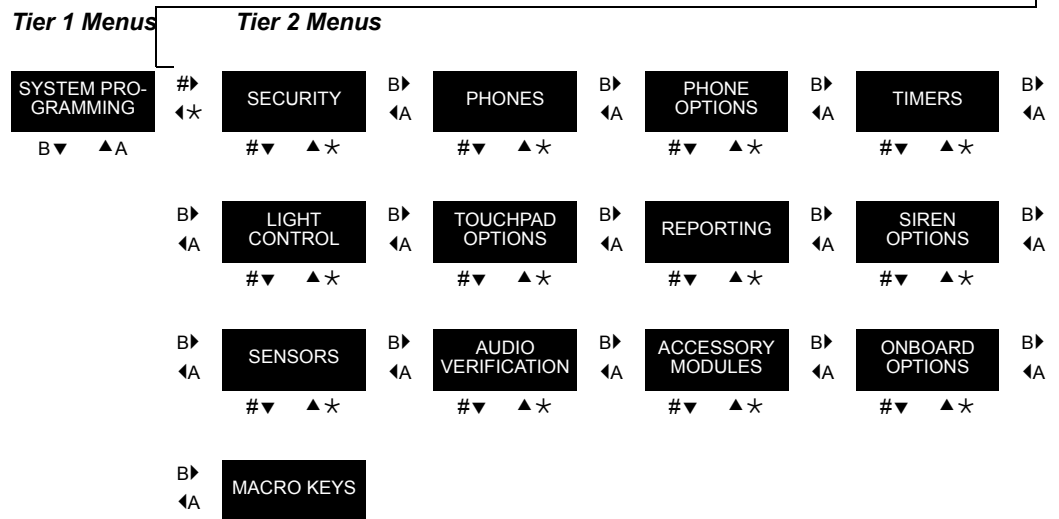

Figure 29. Tier 1 and Tier 2 Program Menus

Arrows pointing right or down represent pressing B or # to advance forward through the menus. Arrows pointing left or up represent pressing A or \* to move through the menus in reverse. Only when *SYSTEM PROGRAMMING* is displayed can you advance to tier 2 menus.

Only when a specific menu is displayed can you advance to those menu settings. For example, from the *SENSORS* menu pressing # gives you access to learning sensors, programming sensor text, deleting sensors, and viewing/editing sensor programming. Settings in tier 2 menus can also be accessed by entering shortcut numbers. See the section, “Programming Tier 2 Menu Items” for complete details.

## **Programming Tier 1 Menu Items**

This section guides you through programming tier 1 menu items as they appear in sequence. The exact order you follow will depend on whether you’re installing a new system or changing programming in an existing system.

### **Demo Kit Mode (System Programming)**

(Default = off) Determines whether the panel is used for a standard installation (off) or as a demo kit (on). When the Demo Kit option is on, only sensors learned into groups 01 and 03, duress code use, and phone test (8 + System Master Code + 2) will be reported. Turning on this feature and performing a memory clear changes the following settings:

- Partition 1 Master Code = 1000
- Partition 2 Master Code = 2000
- User Code 00 = 1001 (partition 1 code—can also be used to jump to partition 2)
- User Code 01 = 1002 (partition 1 code—can also be used to bypass sensors)
- User Code 02 = 2001 (partition 2 code—can also be used for remote or off-site access)
- User Code 03 = 2002 (partition 2 code—can also be used to perform system tests)
- User Code 04 = 1122 (partition 1 code—can also be used to jump to partition 2, for remote or off-site access, and system tests)
- User Code 05 = 2233 (partition 2 code—can also be used to jump to partition 1, for remote or off-site access, bypassing sensors, and system tests)
- Partition 1 House Code = 255 (P)
- Partition 2 House Code = 254 (O)
- Zone 1 (hardwire input 1) = Group 10, Front Door
- Zone 2 (hardwire input 2) = Group 13, Bedroom Window
- Zone 3 (hardwire input 3) = Group 17, Living Room Motion Sensor
- Zone 4 (hardwire input 4) = Group 1, Panic
- Zone 5 (wireless, keychain touchpad, ID F00201) = Group 01, (no text)
- Zone 6 (wireless, DWS, ID A00206) = Group 13, Kitchen Window
- COMM FAILURE = off Demo Kit = on
- AVM code = 1212
- Entry Delay = 8 sec
- Exit Delay = 8 sec
- Extended Delay = 1 minute
- Siren Timeout = 2 minutes

#### ➤ **To turn Demo Kit Mode off or on:**

1. With the display showing *DEMO KIT MODE OFF/ON (current setting)*, press 1 (off) or 2 (on), then press #.
2. The display flashes the entered setting, then stops after pressing # and displays *DEMO KIT MODE OFF/ON (new setting)*.

### **Partition 1 Copy (System Programming)**

(Default = none) After programming all settings pertaining to partition 1, you can make an exact copy to use for partitions 2-6. This helps reduce programming time when the system is set up for multiple partitions. If there are certain settings that are unique to partitions 2-6, simply advance to the appropriate menu and make the necessary changes.

#### ➤ **To Copy Partition 1:**

- ♦ With the display showing *PARTITION 1 COPY*, press # + installer CODE + #. The display flashes, then stops after pressing # and shows *DONE*.

### Clear Memory (System Programming)

Clearing memory deletes all existing programming information (except the Dealer Code).

**Note**  
Clearing the memory will erase onboard hardware zone factory programming.

➤ **To Clear Panel Memory:**

1. With the system in program mode, press A or B until the display shows *CLEAR MEMORY*.
2. Press # and the display shows *ENTER CODE TO CLEAR MEMORY*.
3. Enter the 4-digit installer or dealer code (if programmed) + #. After about five seconds, the system restarts and the panel scans the bus to learn all bus devices.

If the system doesn't respond as described, repeat step 3.

### Programming Tier 2 Menu Items

This section guides you through programming tier 2 menu items as they appear in sequence. Figure 27 shows the menus available on tier 2.

Each menu on tier 2 represents a group of settings related to the menu name. Some tier 2 menus break down into settings that affect the whole system (global) or a specific partition.

#### Using Shortcut Numbers

To go directly to a setting in tier 2, you can enter the shortcut number for that setting. Shortcut numbers in this manual appear in parenthesis ( ), next to the setting name. For example, this heading shows the Downloader Code global shortcut to be 0000.

<b>Downloader Code (0000)</b>	<b>Security-Global (Default = 12345)</b>
-------------------------------	--

Menus with partition settings have the series of shortcut numbers in parenthesis. For example, this heading shows the Account Number partition shortcut number series to be 0010 - 0060.

<b>Account Number (0010 - 0060)</b>	<b>Security-Partition 1-6 (Default = 00000)</b>
-------------------------------------	---

The bold digit identifies the partition. To go directly to partition 3 account number, you would enter 0030.

Shortcut numbers can be used from any setting location within tier 2.

➤ **To advance to tier 2 program menus:**

- ◆ With the system in program mode and the display showing *SYSTEM PROGRAMMING*, press # once. The display should show *SECURITY*.

### Security Menu

The *SECURITY* menu lets you choose whether security settings affect the whole system (global) or a specific partition.

➤ **To access global or partition security menu items:**

1. With the display showing *SECURITY*, press #. The display should show *GLOBAL*.
2. Press # again to advance to global settings, or press A or B to display *PARTITION n*, then press # to advance to selected partition 1-6 settings.

The following describes how to program the Security settings that appear under *GLOBAL*.

<b>Downloader Code (0000)</b>	<b>Security-Global (Default = 12345)</b>
<p>The 5-digit downloader code is used in conjunction with downloader programming. The downloader operator must have the panel account number and downloader code in order to perform any programming.</p> <p><b>Note</b> The Downloader Code cannot be deleted from panel memory. To change the Downloader Code to its default setting, enter 12345 in the procedure to the right. The Downloader Code will be reset to defaults during a Memory Clear only if the Dealer Code is not set OR if the Dealer Code is used to initiate the Memory Clear.</p> <p><b>Note</b> Downloader programming has not been investigated by UL.</p>	<p>➤ <b>To program a Downloader Code:</b></p> <ol style="list-style-type: none"> <li>1. With the display showing <i>DOWNLOADER CODE nnnnn (current code)</i>, enter the desired 5-digit code, + #. The display flashes the entered code.</li> <li>2. Press # and the display shows the new code.</li> </ol>

<b>Installer Code (0001)</b>	<i>Security-Global (Default = 4321)</i>
<p>The 4-digit installer code is used for entering program mode and changing system settings. If a dealer code is programmed, only those settings not associated with phone numbers and the Downloader Code can be changed.</p> <p><b>Note</b> The Installer Code cannot be deleted or cleared from panel memory. To change the Installer Code to its default setting, enter 4321.</p>	<p>➤ <b>To program a Installer Code:</b></p> <ol style="list-style-type: none"> <li>1. With the display showing <i>INSTALLER CODE nnnn (current code)</i>, enter the desired 4-digit code. The display flashes the entered code.</li> <li>2. Press # and the display shows the new code.</li> </ol>

<b>Dealer Code (0002)</b>	<i>Security-Global (Default = none)</i>
<p>The 4-digit dealer code is used to prevent unauthorized persons from changing the programmed central station phone numbers and Downloader Code. When this feature is enabled, central station phone numbers and Downloader Code cannot be changed (unless you enter the program mode by using the dealer code). All <i>other</i> system settings are still accessible by entering the program mode with the installer code.</p> <p><b>Note</b> The Dealer Code cannot be deleted by clearing panel memory.</p>	<p>➤ <b>To program a Dealer Code:</b></p> <ol style="list-style-type: none"> <li>1. With the display showing <i>DEALER CODE ****</i>, enter the desired 4-digit code. The display flashes the entered code.</li> <li>2. Press # and the display shows the new code.</li> </ol> <p>➤ <b>To delete a Dealer Code:</b></p> <ol style="list-style-type: none"> <li>1. With the display showing <i>DEALER CODE nnnn (current code)</i>, press D. The display shows <i>DEALER CODE ****</i>.</li> </ol>

<b>Access Code Lock (0003)</b>	<i>Security-Global (Default = on)</i>
<p>This setting determines whether or not the panel will include Access Codes when sending user information to the automation module. When this option is on, it means the Access Codes are not sent.</p>	<p>➤ <b>To turn Access Code Lock off or on:</b></p> <ol style="list-style-type: none"> <li>1. With the display showing <i>ACCESS CODE LOCK ON/OFF</i>, press 1 (off) or 2 (on). The display flashes the entered setting.</li> <li>2. Press # and the display shows the new setting.</li> </ol>

<b>Partition Security (0004)</b>	<i>Security-Global (Default = on)</i>
<p>Controls whether an access code is required for partition jumping. When turned on, users must jump partitions with an access code by pressing 8 + CODE + 6 + PTN. When turned off, users can jump partitions without an access code by pressing 7 + 4 + PTN n (n = 1-6).</p> <p><b>Note</b> Regardless of the setting, an access code can always be used to jump partitions.</p>	<p>➤ <b>To turn Partition Security off or on:</b></p> <ol style="list-style-type: none"> <li>1. With the display showing <i>PTN SECURITY (current setting)</i>, press 1 (off) or 2 (on). The display flashes the entered setting.</li> <li>2. Press # and the display shows the new setting.</li> </ol>



**Multi-Partition Arm/Disarm (0005)**

Security-Global (Default = none)

Controls which partitions can be armed/disarmed simultaneously when using a touchpad and access code assigned to those partitions. When enabled, users can arm/disarm selected partitions using an authorized access code. When disabled, multiple partitions cannot be armed/disarmed simultaneously.

- At least two partitions must be selected for this feature to work.
- Touchpads must be assigned to at least one of the selected partitions of this menu for this feature to work.
- Access codes must be assigned to all selected partitions of this menu for this feature to work. If the partition assignment for a specific access code does not match the partitions selected in this menu, only those partitions common to both menu settings can be armed/disarmed simultaneously with that code.
- A partition cannot be armed/disarmed if it is being controlled by another source at that time.
- All arming modifiers (No Delay, Latchkey, etc.) except Silent affect all partitions being armed. Only the arming partition can be armed silently.
- When arming multiple partitions, any conditions that prevent arming (open sensor, trouble, active alarm, etc.) are identified on touchpad displays with the affected partition number flashing. The normal protest/auto force arm sequence follows, or pressing \* cancels the arming request.
- When disarming multiple partitions, any partitions in alarm have the affected partition number flashing on touchpad displays. Pressing # cancels all alarms in the selected partitions. Alarm memory information is then displayed for all canceled alarms.

**➤ To enable Multi-Partition Arm/Disarm:**

1. With the display showing *MULTI-PTN ARM/DISARM* <sub>1</sub>, press 1-6 to enter the desired partitions (at least two). The display flashes the entered partitions.
2. Press # and the display stops flashing.

**➤ To disable Multi-Partition Arm/Disarm:**

1. With the display showing *MULTI-PTN ARM/DISARM n n n n n n n n*, select all of the displayed partitions by entering the appropriate partition number. The partition numbers disappear from the display.
2. Press #.

<b>Keychain TP PTN (0006)</b>	<b>Security-Global (Default = keychain TP partition assignment)</b>
<p>Controls which partitions the selected keychain touchpad can arm/disarm. When enabled, the selected keychain touchpad can arm/disarm the partitions selected in this menu. When disabled, the selected keychain touchpad cannot arm/disarm multiple partitions.</p> <ul style="list-style-type: none"> <li>• If no keychain touchpads are learned into panel memory, this menu displays NOT AVAILABLE.</li> <li>• When keychain touchpads are learned into panel memory, two sub-menus appear. The first one lets you view keychain touchpad assignments similar to that of viewing learned sensors (sensor #, partition learned into, sensor group, etc.). The second sub-menu lets you view and change the multi-partition arming assignments for that keychain touchpad.</li> <li>• At least two partitions must be selected for this feature to work.</li> <li>• Keychain touchpads can arm/disarm multiple partitions only for those partitions set up in the MULTI-PARTITION ARM/DISARM menu.</li> <li>• A partition cannot be armed/disarmed if it is being controlled by another source at that time.</li> <li>• When arming multiple partitions from a keychain touchpad (press and release Lock button), any conditions that prevent arming (open sensor, trouble, active alarm, etc.) are identified on touchpad displays in the partition where that condition exists. Touchpad displays in all other partitions being armed display <i>PROTEST</i>. The normal protest/auto force arm sequence follows, or pressing * on any touchpad in a partition being armed cancels the arming request. Pressing the Lock button again during a protest bypasses any open sensors in the affected partitions and arms those partitions.</li> <li>• When disarming multiple partitions with a keychain touchpad and alarms are active in one or more of the assigned partitions: <ul style="list-style-type: none"> <li>a). Protest beeps sound for five minutes in all partitions being disarmed;</li> <li>b). Partitions in alarm where sirens have timed out sound protest beeps for five minutes;</li> <li>c). Partitions in alarm with active sirens continue sounding the alarm.</li> </ul> </li> </ul> <p>In any case where alarms are active the premises may not be safe to enter. The user has these options: <b>1).</b> Leave and call for help from a safe location; <b>2).</b> If entering the premises anyway, go to a hardwired touchpad and check the system status to determine the alarm. Disarm and alarm memory is displayed for all assigned partitions; <b>3).</b> Press the keychain touchpad Unlock button a second time (within the five minute protest period) to disarm all assigned partitions and cancel all alarms, then go to a hardwire touchpad and check alarm memory.</p>	<p>➤ <b>To enable Keychain TP PTN:</b></p> <ol style="list-style-type: none"> <li>1. Learn all keychain touchpads into panel memory (see <i>LEARN SENSORS</i> menu).</li> <li>2. Enter this menu (display showing <i>KEYCHAIN TP PTN</i>), then press #. The display shows the lowest touchpad sensor number assignment such as: <i>S1 P1 G0 TP RF</i> where S1 is sensor 1, P1 is partition 1, G0 is sensor group 0, TP is touchpad and RF is wireless.</li> <li>3. Press # to accept this keychain touchpad or press A or B until the desired keychain touchpad appears, then press #. The display shows <i>ARM PARTITION</i>.</li> <li>4. Enter the desired partitions 1-6 (at least two). The display flashes the entered partitions.</li> <li>5. Press # and the display stops flashing.</li> </ol> <p>➤ <b>To disable Keychain TP PTN:</b></p> <ol style="list-style-type: none"> <li>1. Follow steps 2 and 3 above.</li> <li>2. Enter the partition numbers that are displayed (except for the partition you assigned the touchpad when it was learned). Each will disappear from the display with the touchpad's original partition number left flashing.</li> <li>3. Press # and the display stops flashing.</li> </ol>

The following sections describe the Security settings that appear under *PARTITION 1-6*.

<b>Account Number (0010 - 0060)</b>	<b>Security-Partition 1-6 (Default = 00000)</b>
<p>The account number is used as panel (or customer) identification for the central monitoring station. The panel sends the account number every time it reports to the central station. Account numbers must be 1 to 10 characters long.</p> <p>Alpha characters A-F can be assigned to the account number by pressing and holding buttons 1-6 respectively, until the character appears.</p> <p><b>Note</b> When using the CID reporting format, the letter "A" is reported as a "0".</p>	<p>➤ <b>To program an Account Number:</b></p> <ol style="list-style-type: none"> <li>1. With the display showing <i>ACCOUNT NUMBER mnnnn (current number)</i>, enter the desired account number. The display flashes the entered number.</li> <li>2. Press # and the display shows the new number.</li> </ol>

<b>Quick Arm (0011 - 0061)</b>	<i>Security-Partition 1-6 (Default = off)</i>
<p>Quick Arm allows system arming without using an access code. When Quick Arm is on, the system arming level can be increased from Level 1-OFF to LEVEL 2-STAY, from Level 1-OFF to LEVEL 3-AWAY, or from Level 2-STAY to LEVEL 3-AWAY, without entering an access code.</p> <p>A valid access code is still required to decrease the arming level or disarm the system.</p>	<p>➤ <b>To turn Quick Arm off or on:</b></p> <ol style="list-style-type: none"> <li>1. With the display showing <i>QUICK ARM OFF/ON (current setting)</i>, press 1 (off) or 2 (on). The display flashes the entered setting.</li> <li>2. Press # and the display shows the new setting.</li> </ol>

<b>Quick Exit (0012 - 0062)</b>	<i>Security-Partition 1-6 (Default = on)</i>
<p>This setting determines whether or not users can open and close a standard entry/exit door without causing an alarm (while the system is armed).</p> <p>This feature would be useful if the user wants to go out to get the morning paper while the system is armed. This feature also allows the user to leave the armed premises without having to disarm and re-arm the system.</p> <p>When Quick Exit is on, pressing D on a touchpad (while the system is armed) starts a 2-minute timer that allows one standard entry/exit door (sensor groups 10 and 19 only) to be activated once (opened, then closed).</p> <p>When this feature is turned off, the system must be disarmed before any protected door is opened.</p> <p><b>Note</b> For UL Listed installations, this feature must be set to off.</p>	<p>➤ <b>To turn Quick Exit off or on:</b></p> <ol style="list-style-type: none"> <li>1. With the display showing <i>QUICK EXIT OFF/ON (current setting)</i>, press 1 (off) or 2 (on). The display flashes the entered setting.</li> <li>2. Press # and the display shows the new setting.</li> </ol>

<b>Exit Extension (0013 - 0063)</b>	<i>Security-Partition 1-6 (Default = on)</i>
<p>This setting determines whether or not the user can re-enter and exit again through an entry or exit delay door (without disarming and re-arming the system). This helps prevent exit faults and false alarms by allowing users to re-enter the premises for a forgotten item.</p> <p>When Exit Extension is on, the panel restarts the exit delay timer if the user re-enters the premises through a standard delay door before the standard exit delay time expires.</p> <p>When this feature is off, the exit delay timer does not restart if the user re-enters the premises, forcing the user to disarm the system to avoid setting off an accidental alarm.</p>	<p>➤ <b>To turn Exit Extension off or on:</b></p> <ol style="list-style-type: none"> <li>1. With the display showing <i>EXIT EXTENSION OFF/ON (current setting)</i>, press 1 (off) or 2 (on). The display flashes the entered setting.</li> <li>2. Press # and the display shows the new setting.</li> </ol>

<b>Keyswitch Sensor (0014 - 0064)</b>	<i>Security-Partition 1-6 (Default = none)</i>
<p>This feature lets users arm and disarm the system using either a keyswitch wired to a hardwire zone input or a wireless door/window sensor.</p> <p><b>Note</b> <i>It is recommended that keyswitch sensors are learned into group 28.</i></p> <p>For example, if sensor 1 is designated as the keyswitch sensor and the system is disarmed, then tripping sensor 1 could arm the system to AWAY. If the system is armed to STAY or AWAY, then tripping the sensor could disarm the system (depending on keyswitch style).</p> <p>The panel reports opening, closing, and force armed reports (if turned on) to the central monitoring station.</p> <p><b>Note</b> <i>A bypassed keyswitch sensor cannot arm or disarm the system. During an audible alarm, keyswitch sensors can disarm the system (which sends a cancel report to the central monitoring station), but cannot arm the system. The system can be armed only after the siren timeout expires. Keyswitch sensors test the same as any other sensor and do not arm or disarm the system during a sensor test.</i></p>	<p>➤ <b>To assign a Keyswitch Sensor:</b></p> <ol style="list-style-type: none"> <li>1. With the display showing <i>KEYSWITCH SENSOR nn (current sensor number)</i>, enter the desired sensor number (01–96). The display flashes the entered sensor number.</li> <li>2. Press # and the display shows the new number.</li> </ol> <p>➤ <b>To delete a Keyswitch Sensor:</b></p> <ol style="list-style-type: none"> <li>1. With the display showing <i>KEYSWITCH SENSOR nn (current sensor number)</i>, press D to erase the keyswitch sensor attribute.</li> </ol>

<b>Keyswitch Style (0015 - 0065)</b>	<b>Security-Partition 1-6 (Default = transition)</b>
<p>This feature allows users to select how they want the system to behave when armed/disarmed by a keyswitch sensor. The choices are as follows:</p> <p><b>Transition:</b> If keyswitch style is set to transition and the keyswitch sensor is tripped (opened) when the system is disarmed (level 1), the panel will automatically arm to AWAY (level 3). If the sensor is tripped (opened) when the system is armed to AWAY (level 3) or STAY (level 2), the panel will automatically disarm.</p> <p><b>State:</b> If keyswitch style is set to state, when the keyswitch sensor is tripped (opened) the panel arms to AWAY (level 3). If the sensor is restored (closed) the panel disarms.</p> <p>Opening, closing, and force arming reports (if turned on) are reported to the central station for both keyswitch styles.</p>	<p>➤ <b>To assign a Keyswitch Style:</b></p> <ol style="list-style-type: none"> <li>1. With the display showing <i>KEYSWITCH STYLE TRANSITION/STATE (current setting)</i>, press 1 for Transition or 2 for State. The display flashes the entered setting.</li> <li>2. Press # and the display shows the new setting.</li> </ol>

<b>Duress Code (0016 - 0066)</b>	<b>Security-Partition 1-6 (Default = none)</b>
<p>The duress code is a unique 4-digit access code that allows users to operate the system and, at the same time, instructs the panel to send a silent alarm report to the central station.</p> <p>Do not use a duress code unless it is absolutely necessary. Using duress codes often results in false alarms due to code entry errors. If a duress code <i>is</i> absolutely necessary, use it with an audio verification module (AVM) to reduce false alarms and accidental dispatches.</p> <p><b>Note</b> To use this feature, the <i>Duress Option</i> setting under the reporting—partition 1 (2) menu must be turned on.</p>	<p>➤ <b>To program a Duress Code:</b></p> <ol style="list-style-type: none"> <li>1. With the display showing <i>DURESS CODE ****</i>, enter the desired 4-digit duress code. The display flashes the entered setting.</li> <li>2. Press # and the display shows the new code.</li> </ol> <p>➤ <b>To delete a Duress Code:</b></p> <ol style="list-style-type: none"> <li>1. With the display showing <i>DURESS CODE nnnn (current code)</i>, press D. The display shows <i>DURESS CODE ****</i>.</li> </ol>

### Phones Menu

The *PHONES* menu lets you set up central station reporting for the system. The following describes how to program the settings that appear under *CS PHONE 1-3*.

<b>Phone Number (cs phone 1: 01000, cs phone 2: 01010, cs phone 3: 01020)</b>	<b>Phones-CS 1-3 (Default = none)</b>
<p>This setting is used for programming the central station receiver phone number. Phone numbers can be 1 to 24 digits long, including pauses or * and # characters.</p> <p>To enter pauses, press C. To enter *, press and hold 7 for about two seconds. To enter #, press and hold 9 for about two seconds.</p> <p><b>Note</b> The <i>PHONE NUMBER</i> menus are not accessible if a Dealer Code is programmed and the Installer Code is used to enter installer programming mode. To access these menus when a Dealer Code is programmed, you must enter installer programming mode using the Dealer Code.</p> <p>Call-waiting services should be disabled to prevent interrupting panel communication to the central monitoring station. To program a dialing prefix that disables call-waiting, see the <i>Call Wait Cancel</i> setting under the menu <i>PHONE OPTIONS—GLOBAL</i>.</p> <p>For UL 1610 &amp; 1635 installations, a phone number must be programmed.</p>	<p>➤ <b>To program a Central Station Phone Number:</b></p> <ol style="list-style-type: none"> <li>1. With the display showing <i>PHONE NUMBER_ (or current number)</i>, enter the desired phone number. The display flashes the entered number.</li> <li>2. Press # and the display shows the new number.</li> </ol> <p>➤ <b>To delete a Central Station Phone Number:</b></p> <ul style="list-style-type: none"> <li>◆ With the display showing <i>PHONE NUMBER (current number)</i>, press D. The display shows <i>PHONE NUMBER_</i>.</li> </ul>

**High Level Rpts** (cs phone 1: 01001, cs phone 2: 01011, cs phone 3: 01021) Phones-CS 1-3 (Defaults:1 = on, 2&3 = off)

When this setting is on, the following conditions report to the central station:

- Fire, Police, Auxiliary, and Duress alarms
- No Activity
- Receiver Failure (or jam)
- Tamper conditions, including Zone Tamper and System Tamper (40 incorrect key presses or touchpad supervisory)
- Entering or exiting Sensor Test mode
- Phone Test

**Note**  
For UL 1610 & 1635 installations, this feature must be set to on.

- **To turn High-Level Reports off or on:**
1. With the display showing *HIGH LEVEL RPTS OFF/ON (current setting)*, press 1 (off) or 2 (on). The display flashes the entered setting.
  2. Press # and the display shows the new setting.

**Low Level Rpts** (cs phone 1: 01002, cs phone 2: 01012, cs phone 3: 01022) Phones-CS 1-3 (Defaults:1 = on, 2&3 = off)

When this setting is on, the following non-alarm conditions report to the central station:

- Force Armed
- Hardwire Zone Trouble (open or short)
- Supervisory (wireless devices)
- Low Battery (wireless devices)
- Phone Test
- Other non-alarm related conditions

**Note**  
For UL 1610 & 1635 installations, this feature must be set to on.

- **To turn Low-Level Reports off or on:**
1. With the display showing *LOW LEVEL RPTS OFF/ON (current setting)*, press 1 (off) or 2 (on). The display flashes the entered setting.
  2. Press # and the display shows the new setting.

**Exception Rpts** (cs phone 1: 01003, cs phone 2: 01013, cs phone 3: 01023) Phones-CS 1-3 (Default = off)

When this setting is on, the panel reports to the central station if the system is not armed or disarmed at the specified schedule times.

- **To turn Exception Reports off or on:**
1. With the display showing *EXCEPTION RPTS OFF/ON (current setting)*, press 1 (off) or 2 (on). The display flashes the entered setting.
  2. Press # and the display shows the new setting.

**Open/Close Rpts** (cs phone 1: 01004, cs phone 2: 01014, cs phone 3: 01024) Phones-CS 1-3 (Default = off)

This setting determines whether opening and closing reports are sent to the central station. When turned on, the panel sends a closing report when the system is armed and an opening report when the system is disarmed.

**Note**  
To use this feature, the *Opening Reports and Closing Reports* settings under the *REPORTING* menu must be turned on for that partition.

- **To turn Opening/Closing Reports off or on:**
1. With the display showing *OPEN/CLOSE RPTS OFF/ON (current setting)*, press 1 (off) or 2 (on). The display flashes the entered setting.
  2. Press # and the display shows the new setting.

**Backup** (cs phone 1: 01005, cs phone 2: 01015, cs phone 3: 01025) Phones-CS 1-3 (Defaults:1 = on, 2&3 = off)

This setting determines whether or not the panel uses another programmed central station phone number for reporting if attempts with the first number are unsuccessful.

When Back Up is off, the panel will make up to eight attempts to deliver a report with the programmed phone number.

When Back Up is set to on, the panel makes up to 16 attempts to deliver the report, alternating between the programmed phone number and the backup phone number.

CS PHONE 1 is backed up by CS PHONE 2.  
 CS PHONE 2 is backed up by CS PHONE 1.  
 CS PHONE 3 is backed up by CS PHONE 1.

➤ **To turn Backup off or on:**

1. With the display showing *BACK UP OFF/ON (current setting)*, press 1 (off) or 2 (on). The display flashes the entered setting.
2. Press # and the display shows the new setting.

**SIA/CID Reporting** (cs phone 1: 01006, cs phone 2: 01016, cs phone 3: 01026) Phones-CS 1-3 (Default = CID)

This setting determines whether the panel uses the SIA or CID (Contact ID) reporting format for central station communication.

➤ **To select SIA or CID reporting:**

1. With the display showing *REPORTING FORMAT SIA/CID (current setting)*, press 1 (for SIA) or 2 (for CID). The display flashes the entered setting.
2. Press # and the display shows the new setting.

**Cellular Backup** (cs phone 1: 01007, cs phone 2: 01017, cs phone 3: 01027) Phones-CS 1-3 (Defaults:1 = on, 2&3 = off)

This setting determines whether the panel uses cellular communication for reporting if attempts using a landline are unsuccessful.

➤ **To turn Cellular Backup off or on:**

1. With the display showing *CELLULAR BACKUP*, press 1 (off) or 2 (on). The display flashes the entered setting.
2. Press # and the display shows the new setting.

The following describes how to program the Phones settings that appear under *PAGER PHONE 1-5*.

**Phone Number** (pager 1: 01030, pager 2: 01040, pager 3: 01050, pager 4: 01060, pager 5: 01070) Phones-Pager Phone 1-5 (Default = none)

This setting is used for programming a phone number that communicates to a pager. Phone numbers can be 1 to 24 digits long and include pauses, a skylink number, and 7-digit PIN number.

**Note**  
*Call-waiting services should be disabled to prevent interrupting panel communication to the pager(s). To program a dialing prefix that disables call-waiting, see the Call Wait Cancel setting under the menu PHONE OPTIONS—GLOBAL.*

To enter pauses, press C.  
 To enter \*, press and hold 7 for about two seconds.  
 To enter #, press and hold 9 for about two seconds.

➤ **To program a Pager Phone Number:**

1. With the display showing *PHONE NUMBER \_ (or current number)*, enter the desired pager phone number. The display flashes the entered number.
2. Press # and the display shows the new setting.

➤ **To delete a Pager Phone Number:**

1. With the display showing *PHONE NUMBER (current number)*, press D. The display shows *PHONE NUMBER \_*.

<b>High Level Rpts</b> (pager 1: 01031, pager 2: 01041, pager 3: 01051, pager 4: 01061, pager 5: 01071)	Phones-Pager Phone 1-5 (Default = on)
<p>This setting determines whether the following alarm conditions report to a pager:</p> <ul style="list-style-type: none"> <li>• Fire, Police, Auxiliary, and Duress alarms</li> <li>• No Activity</li> <li>• Receiver Failure (or jam)</li> <li>• Tamper conditions, including Zone Tamper and System Tamper (40 incorrect key presses or touchpad supervisory)</li> <li>• Entering or exiting Sensor Test mode</li> <li>• Phone Test</li> </ul>	<p>➤ <b>To turn High-Level Reports off or on:</b></p> <ol style="list-style-type: none"> <li>1. With the display showing <i>HIGH LEVEL RPTS OFF/ON (current setting)</i>, press 1 (off) or 2 (on). The display flashes the entered setting.</li> <li>2. Press # and the display shows the new setting.</li> </ol>

<b>Low Level Rpts</b> (pager 1: 01032, pager 2: 01042, pager 3: 01052, pager 4: 01062, pager 5: 01072)	Phones-Pager Phone 1-5 (Default = off)
<p>This setting determines whether the following non-alarm conditions report to a pager:</p> <ul style="list-style-type: none"> <li>• Force Armed</li> <li>• Hardwire Zone Trouble (open or short)</li> <li>• Supervisory (wireless devices)</li> <li>• Low Battery (wireless devices)</li> <li>• Phone Test</li> <li>• Other non-alarm related conditions</li> </ul>	<p>➤ <b>To turn Low-Level Reports off or on:</b></p> <ol style="list-style-type: none"> <li>1. With the display showing <i>LOW LEVEL RPTS OFF/ON (current setting)</i>, press 1 (off) or 2 (on). The display flashes the entered setting.</li> <li>2. Press # and the display shows the new setting.</li> </ol>

<b>Exception Rpts</b> (pager 1: 01033, pager 2: 01043, pager 3: 01053, pager 4: 01063, pager 5: 01073)	Phones-Pager Phone 1-5 (Default = off)
<p>This setting determines whether the panel reports to a pager if the system is not armed or disarmed at the specified schedule times, if open/close reports are turned on.</p>	<p>➤ <b>To turn Exception Reports off or on:</b></p> <ol style="list-style-type: none"> <li>1. With the display showing <i>EXCEPTION RPTS OFF/ON (current setting)</i>, press 1 (off) or 2 (on). The display flashes the entered setting.</li> <li>2. Press # and the display shows the new setting.</li> </ol>

<b>Open/Close Rpts</b> (pager 1: 01034, pager 2: 01044, pager 3: 01054, pager 4: 01064, pager 5: 01074)	Phones-Pager Phone 1-5 (Default = off)
<p>This setting determines whether opening and closing reports are sent to a pager. When turned on, the panel sends a closing report when the system is armed and an opening report when the system is disarmed.</p> <p><b>Note</b> To use this feature, the opening reports and closing reports settings under the REPORTING menu must be turned on for that partition.</p>	<p>➤ <b>To turn Opening/Closing Reports off or on:</b></p> <ol style="list-style-type: none"> <li>1. With the display showing <i>OPEN/CLOSE RPTS OFF/ON (current setting)</i>, press 1 (off) or 2 (on). The display flashes the entered setting.</li> <li>2. Press # and the display shows the new setting.</li> </ol>

<b>Latchkey Reports</b> (pager 1: 01035, pager 2: 01045, pager 3: 01055, pager 4: 01065, pager 5: 01075)	Phones-Pager Phone 1-5 (Default = on)
<p>This setting determines whether the panel reports to a pager when the system is armed or disarmed, according to latchkey time scheduling.</p>	<p>➤ <b>To turn Latchkey reports off or on:</b></p> <ol style="list-style-type: none"> <li>1. With the display showing <i>LATCHKEY RPTS OFF/ON (current setting)</i>, press 1 (off) or 2 (on). The display flashes the entered setting.</li> <li>2. Press # and the display shows the new setting.</li> </ol>

<b>Streamlining</b> (pager 1: 01036, pager 2: 01046, pager 3: 01056, pager 4: 01066, pager 5: 01076)	<i>Phones-Pager Phone 1-5 (Default = on)</i>
This setting determines whether the panel includes (off) or excludes (on) the account number when reporting to a pager.	<ul style="list-style-type: none"> <li>➤ <b>To turn Streamlining off or on:</b> <ol style="list-style-type: none"> <li>1. With the display showing <i>STREAMLINING OFF/ON (current setting)</i>, press 1 (off) or 2 (on). The display flashes the entered setting.</li> <li>2. Press # and the display shows the new setting.</li> </ol> </li> </ul>

<b>Ptn Assignment</b> (pager 1: 01037, pager 2: 01047, pager 3: 01057, pager 4: 01067, pager 5: 01077)	<i>Phones-Pager Phone 1-5 (Default = 1)</i>
This setting determines the partition that reports to a pager. All partitions can be assigned to report to a single pager.	<ul style="list-style-type: none"> <li>➤ <b>To set up Partition Assignments for pager reporting:</b> <ol style="list-style-type: none"> <li>1. With the display showing <i>PARTITION ASSIGN 1-6 (current setting)</i>, press 1-6 to select the desired partitions. The display flashes the entered settings.</li> <li>2. Press # and the display stops flashing.</li> </ol> </li> </ul>

The following describes how to program the settings that appear under *DOWNLOADER PHONE*.

<b>Phone Number</b> (01090)	<i>Phones-Downloader Phone (Default = none)</i>
Use this setting to enter the phone number of an off-site computer that can be used to program the panel through the phone line. Phone numbers can be 1 to 24 digits long, including pauses or * and # characters.	<ul style="list-style-type: none"> <li>➤ <b>To program a downloader phone number:</b> <ol style="list-style-type: none"> <li>1. With the display showing <i>PHONE NUMBER (current number)</i>, enter the desired phone number. The display flashes the entered number.</li> <li>2. Press # and the display shows the new setting.</li> </ol> </li> <li>➤ <b>To delete a downloader phone number:</b> <ol style="list-style-type: none"> <li>1. With the display showing <i>PHONE NUMBER (current number)</i>, press D to erase the number. The display shows <i>PHONE NUMBER_</i>.</li> </ol> </li> </ul>
<p><b>Note</b>  <i>Call-waiting services should be disabled to prevent interrupting panel communication to the downloader. To program a dialing prefix that disables call-waiting, see the Call Wait Cancel setting under the menu PHONE OPTIONS—GLOBAL.</i></p> <p>To enter pauses, press C.  To enter *, press and hold 7 for about two seconds.  To enter #, press and hold 9 for about two seconds.</p>	

### Phone Options Menu

The *PHONE OPTIONS* menu lets you set up system phone access and communications that affect the whole system (global) or a specific partition.

The following describe how to program the Phone Options settings that appear under *GLOBAL*.

<b>Phone Test</b> (02000)	<i>Phone Options-Global (Default = on)</i>
This setting determines if the user can, at any time, test the communication from the panel to the central station or a pager by entering 8 + CODE + 2 (# + 8 + CODE + 2 from a touch-tone phone).	<ul style="list-style-type: none"> <li>➤ <b>To turn the Phone Test setting off or on:</b> <ol style="list-style-type: none"> <li>1. With the display showing <i>PHONE TEST OFF/ON (current setting)</i>, press 1 (off) or 2 (on). The display flashes the entered setting.</li> <li>2. Press # and the display shows the new setting.</li> </ol> </li> </ul>
<p><b>Note</b>  For UL 1610 &amp; 1635 listed installations, this feature must be set to on.</p>	



<b>Auto Phone Test (02001)</b>	<i>Phone Options-Global (Default = off)</i>
<p>This setting determines if the panel sends a phone test automatically to the central station or a pager on a predetermined schedule. (Refer to the “Phone Test Freq.” and “Next Phone Test” settings found under <i>TIMERS—GLOBAL</i>).</p> <p><b>Note</b> For UL 1610 &amp; 1635 listed installations, this feature must be set to on.</p>	<p>➤ <b>To turn Automatic Phone Test off or on:</b></p> <ol style="list-style-type: none"> <li>1. With the display showing <i>AUTO PHONE TEST OFF/ON (current setting)</i>, press 1 (off) or 2 (on). The display flashes the entered setting.</li> <li>2. Press # and the display shows the new setting.</li> </ol>

<b>Auto Test Reset (02002)</b>	<i>Phone Options-Global (Default = on)</i>
<p>This setting determines whether or not the Auto Phone Test interval is reset after any successful report to the central monitoring station. (Refer to the “Phone Test Freq.” and “Next Phone Test” settings found under <i>TIMERS—GLOBAL</i>).</p> <p>When this feature is on, the panel considers any successful report to the central monitoring station to be a successful phone test. Thus, any panel report resets the Next Phone Test setting to the Phone Test Freq. value. The panel only conducts an Auto Phone Test if no other reports have been made during the Phone Test Freq. time period.</p> <p><b>Note</b> <i>Phone Test Freq must be set to 2 or higher for Auto Test Reset to work.</i></p> <p>When this feature is off, an Auto Phone Test is always conducted according to the schedule of the Phone Test Freq. setting, even if the panel makes other reports to the central monitoring station during that time period.</p>	<p>➤ <b>To turn Auto Test Reset off or on:</b></p> <ol style="list-style-type: none"> <li>1. With the display showing <i>AUTO TEST RESET OFF/ON (current setting)</i>, press 1 (off) or 2 (on). The display flashes the entered setting.</li> <li>2. Press # and the display shows the new setting.</li> </ol>

<b>Comm Failure (02003)</b>	<i>Phone Options-Global (Default = on)</i>
<p>This setting determines whether the panel activates trouble beeps to alert users on the premises that communication to the central station failed. Failure notification occurs after the third unsuccessful reporting attempt to the central station/pager.</p> <p>Failure notification can occur immediately if inadequate phone line voltage is detected upon the initial dialing attempt.</p> <p><b>Note</b> For UL Listed installations, Comm Failure must be turned on.</p>	<p>➤ <b>To turn Communication Failure notification off or on:</b></p> <ol style="list-style-type: none"> <li>1. With the display showing <i>COMM FAILURE OFF/ON (current setting)</i>, press 1 (off) or 2 (on). The display flashes the entered setting.</li> <li>2. Press # and the display shows the new setting.</li> </ol>

<b>DTMF Dialing (02004)</b>	<i>Phone Options-Global (Default = on)</i>
<p>This setting determines whether the panel uses DTMF tones (on) or pulse (off) for dialing programmed phone numbers.</p>	<p>➤ <b>To turn DTMF Dialing off or on:</b></p> <ol style="list-style-type: none"> <li>1. With the display showing <i>DTMF DIALING OFF/ON (current setting)</i>, press 1 (off) or 2 (on). The display flashes the entered setting.</li> <li>2. Press # and the display shows the new setting.</li> </ol>

<b>Dialer Abort Delay (02006)</b>	<i>Phone Options-Global (Default = 30 sec.)</i>
<p>This setting determines how much time the user has to abort a panel alarm report.</p> <p><b>Note</b> For UL Listed systems, the combined time for the Entry Delay and Dialer Abort Delay must not exceed 60 seconds.</p>	<p>➤ <b>To change the Dial Abort Delay:</b></p> <ol style="list-style-type: none"> <li>1. With the display showing <i>DIAL ABORT DELAY nm SECS (current setting)</i>, enter the desired time (15–45). The display flashes the entered setting.</li> <li>2. Press # and the display shows the new setting.</li> </ol>

<b>Cancel Message (02007)</b>	<i>Phone Options-Global (Default = on)</i>
<p>This setting determines whether or not the panel displays a cancel message after the user disarms the system to clear an alarm condition.</p>	<p>➤ <b>To turn Cancel Message off or on:</b></p> <ol style="list-style-type: none"> <li>1. With the display showing <i>CANCEL MESSAGE OFF/ON (current setting)</i>, press 1 (off) or 2 (on). The display flashes the entered setting.</li> <li>2. Press # and the display shows the new setting.</li> </ol>

<b>Pager Delay (02008)</b>	<i>Phone Options-Global (Default = 15 sec.)</i>
<p>This setting determines how long a report is delayed to a pager, after the panel dials the pager number.</p> <p><b>Note</b> The Pager Delay time should not be set below 5 seconds, unless absolutely necessary.</p>	<p>➤ <b>To set the Pager Delay time:</b></p> <ol style="list-style-type: none"> <li>1. With the display showing <i>PAGER DELAY nn SECS (current setting)</i>, enter a delay time (0–30). The display flashes the entered setting.</li> <li>2. Press # and the display shows the new setting.</li> </ol>

<b>Call Wait Cancel (02009)</b>	<i>Phone Options-Global (Default = none)</i>
<p>This feature lets you set up a dialing prefix to disable the call waiting feature before the panel makes its first dialing attempt to any programmed central monitoring station or downloader phone number. The prefix can be up to eight digits.</p> <p>To enter pauses, press C. To enter *, press and hold 7 for one second. To enter #, press and hold 9 for one second.</p> <p><b>Note</b> It is recommended that you program two pauses in any Call Wait Cancel dialing prefix to help ensure successful operation of this feature.</p>	<p>➤ <b>To set up Call Wait Cancel:</b></p> <ol style="list-style-type: none"> <li>1. With the display showing <i>CALL WAIT CANCEL _ (or current setting)</i>, enter the desired prefix. The display flashes the entered setting.</li> <li>2. Press # and the display shows the new setting.</li> </ol> <p>➤ <b>To delete the Call Wait Cancel prefix:</b></p> <ol style="list-style-type: none"> <li>1. With the display showing <i>CALL WAIT CANCEL _ (or current setting)</i>, press D.</li> </ol>
<p> <b>DO NOT change this option from its default until verifying with the customer that they have call waiting with their phone service provider. Changing this option from its default without call waiting will prohibit the panel from calling the central station.</b></p> <p><b>Caution</b>      —</p>	

<b>Dial Tone Detect (02010)</b>	<i>Phone Options-Global (Default = on)</i>
<p>When this setting is on, the panel begins dialing as soon as it detects a dial tone. When this feature is off, the panel begins dialing a few seconds after seizing the phone line.</p> <p><b>Note</b> There is no Dial Tone Detect on the last dialing attempt.</p>	<p>➤ <b>To set up Dial Tone Detect:</b></p> <ol style="list-style-type: none"> <li>1. With the display showing <i>DIAL TONE DETECT OFF/ON (current setting)</i>, press 1 (off) or 2 (on). The display flashes the entered setting.</li> <li>2. Press # and the display shows the new setting.</li> </ol>

The following sections describe the Phone Options settings that appear under *PARTITION 1-6*. A Phone Interface/Voice Module must be installed for the system to use the settings under *PHONE OPTIONS—PARTITION 1-6 (except Line Fail Delay)*.

<b>Local Phone Control (0210 - 0260)</b>	<i>Phone Options-Partition 1-6(Default = on)</i>
When this feature is on, the panel can be accessed from a phone on the premises.	<p>➤ <b>To set up Local Phone Control:</b></p> <ol style="list-style-type: none"> <li>1. With the display showing <i>LOCAL PHONE CTRL OFF/ON (current setting)</i>, press 1 (off) or 2 (on). The display flashes the entered setting.</li> <li>2. Press # and the display shows the new setting.</li> </ol>

<b>Remote Access (0211 - 0261)</b>	<i>Phone Options-Partition 1-6 (Default = on)</i>
When this setting is on, the panel can be accessed from an off-site phone.	<p>➤ <b>To turn Remote Access off or on:</b></p> <ol style="list-style-type: none"> <li>1. With the display showing <i>REMOTE ACCESS OFF/ON (current setting)</i>, press 1 (off) or 2 (on). The display flashes the entered setting.</li> <li>2. Press # and the display shows the new setting.</li> </ol>

<b>Ring/Hang/Ring (0212 - 0262)</b>	<i>Phone Options-Partition 1-6 (Default = on)</i>
<p>This setting determines how the panel picks up (seizes) the phone line. Select “on” if an answering machine shares the phone line with the panel. Select “off” if there is no answering machine sharing the phone line with the panel.</p> <p><b>Note</b> <i>The Remote Access setting must be turned on for this feature to work.</i></p> <p>When this feature is on, the person who is calling the panel must use the following procedure:</p> <ol style="list-style-type: none"> <li>1. Listen for one or two full rings.</li> <li>2. Hang up.</li> <li>3. Call the premises again within the next 10–40 seconds. The system answers after the first ring.</li> </ol> <p>When this feature is off, the system answers after 12 full rings.</p>	<p>➤ <b>To turn Ring/Hang/Ring access off or on:</b></p> <ol style="list-style-type: none"> <li>1. With the display showing <i>RING/HANG/RING OFF/ON (current setting)</i>, press 1 (off) or 2 (on). The display begins flashing the entered selection.</li> <li>2. Press # and the display shows the new setting.</li> </ol>

<b>Line Fail Delay (partition 1: 0213)</b>	<i>Phone Options-Partition 1 only (Default = none)</i>
<p>This setting determines the amount of time the partition 1 phone line voltage must be absent before the panel indicates a phone failure trouble condition. If a delay is <i>not</i> programmed (default), the panel will not monitor the phone line voltage.</p> <p><b>Note</b> <i>Line Fail Delay is not available for partitions 2-6 at this time.</i></p>	<p>➤ <b>To set the Line Fail Delay time:</b></p> <ol style="list-style-type: none"> <li>1. With partition 1 selected, press A or B until the display shows <i>LINE FAIL DELAY nm SECS (current setting)</i>.</li> <li>2. Enter the desired time value (10–240 seconds). The display flashes the entered setting. Press # and the display shows the new setting.</li> </ol> <p>➤ <b>To delete the Line Fail Delay time:</b></p> <ol style="list-style-type: none"> <li>1. With partition 1 selected, press A or B until the display shows <i>LINE FAIL DELAY nm SECS (current setting)</i>.</li> <li>2. Press D to delete the current line fail delay time.</li> </ol>

<b>Toll Saver (0214 - 0264)</b>	<i>Phone Options-Partition 1-6 (Default = on)</i>
<p>This setting determines whether the panel answers a phone call on the eighth ring (on) or twelfth ring (off) when a trouble or alarm condition exists.</p>	<p>➤ <b>To turn Toll Saver off or on:</b></p> <ol style="list-style-type: none"> <li>1. With the desired partition selected, press A or B until the display shows <i>TOLL SAVER OFF/ON (current setting)</i>.</li> <li>2. Press 1 (off) or 2 (on). The display flashes the entered setting. Press # and the display shows the new setting.</li> </ol>

<b>Phone Panic (0215 - 0265)</b>	<i>Phone Options-Partition 1-6 (Default = off)</i>
<p>This setting determines whether or not a police panic alarm can be activated from a touch-tone phone. When this feature is on, pressing # + ***** from a touch-tone phone on the premises causes a panic alarm.</p>	<p>➤ <b>To turn Phone Panic off or on:</b></p> <ol style="list-style-type: none"> <li>1. With the desired partition selected, press A or B until the display shows <i>PHONE PANIC OFF/ON (current setting)</i>.</li> <li>2. Press 1 (off) or 2 (on). The display flashes the entered setting. Press # and the display shows the new setting.</li> </ol>

<b>Phone Access Key (0216 - 0266)</b>	<i>Phone Options-Partition 1-6 (Default = #)</i>
<p>This setting determines which touch-tone phone button is used for system access and control.</p> <p>If the Local Phone Control feature is enabled, the user can pick up the phone and press # (within 5 seconds) to access the security system. The panel seizes the phone line and waits for the user to enter system commands. Phone access can be changed from # to * (see the following note).</p> <p><b>Note</b> Use the default setting (#) to avoid conflicts between the security system and other phone devices and services. Many phone devices (such as answering machines, computer modems, and FAX machines) and services (such as call-waiting, call-forwarding, and some banking transactions) require * to initiate their operation, so using * for this security feature could cause conflicts.</p>	<p>➤ <b>To change the Phone Access Key:</b></p> <ol style="list-style-type: none"> <li>1. With the desired partition selected, press A or B until the display shows <i>PHONE ACCESS KEY #/* (current setting)</i>.</li> <li>2. Press 1 (for *) or 2 (for #). The display flashes the entered setting. Press # and the display shows the new setting.</li> </ol>

### **Timers Menu**

The *TIMERS* menu lets you set up the various system feature times that affect the whole system (global) or a specific partition.

The following describes how to program the Timers settings that appear under *GLOBAL*.

<b>Supervisory Time (0300)</b>	<i>Timers-Global (Default = set randomly between 01:00 and 04:00)</i>
<p>This setting determines what time of day the panel sends supervisory, low battery, or auto phone test reports to the central station.</p> <p><b>Note</b> The panel clock must be set with the correct time for accurate supervisory time reporting. See "Time and Date Menu".</p>	<p>➤ <b>To set the Supervisory Time:</b></p> <ol style="list-style-type: none"> <li>1. With the display showing <i>SUPERVISORY TIME HH:MM (current setting)</i>, enter the desired 4-digit time value. For example, enter 0330 to set the supervisory time for 3:30 A.M. The display flashes the entered setting.</li> <li>2. Press # and the display shows the new setting.</li> </ol>

<b>RF Tx Timeout (0302)</b>	<i>Timers-Global (Default = 12 hours)</i>
<p>This setting determines how many hours (2–24) the panel has to receive at least one signal from a wireless sensor (learned into a supervised group). If the panel does not receive a signal from any supervised wireless sensor within the set time, the panel reports a supervisory condition to the central station.</p> <p><b>Note</b> For UL 985, 1610 &amp; 1635 listed installations, the RF Tx Timeout must be set to 4 hours. For UL 1023 listed installations, the RF Tx Timeout must be set to 24 hours.</p>	<p>➤ <b>To set the RF Tx Timeout:</b></p> <ol style="list-style-type: none"> <li>1. With the display showing <i>RF TX TIMEOUT nn HOURS (current setting)</i>, enter the desired timeout value (2–24). The display flashes the entered setting.</li> <li>2. Press # and the display shows the new setting.</li> </ol>

<b>Phone Test Freq. (0303)</b>	<i>Timers-Global (Default = 7 days)</i>
<p>This setting determines how often the panel conducts the automatic phone test (see “Auto Phone Test” under <i>PHONE OPTIONS—GLOBAL</i>). The system can be set to perform an automatic phone test anywhere from every day to every 255 days.</p> <p><b>Note</b> For UL 1610 &amp; 1635 listed installations, this feature must be set to 1.</p>	<p>➤ <b>To set the Phone Test Freq:</b></p> <ol style="list-style-type: none"> <li>1. With the display showing <i>PHONE TEST FREQ nnn DAYS (current setting)</i>, enter the number of days (1–255). The display flashes the entered setting.</li> <li>2. Press # and the display shows the new setting.</li> </ol>

<b>Next Phone Test (0304)</b>	<i>Timers-Global (Default = 7 days)</i>
<p>This setting is used by the Auto Phone Test feature (see <i>PHONE OPTIONS—GLOBAL</i>) to determine when the next automatic phone test should occur. This setting should be the same as, or less than, the Phone Test Freq. setting.</p> <p><b>Note</b> For UL 1610 &amp; 1635 listed installations, this feature must be set to 1.</p>	<p>➤ <b>To set the Next Phone Test:</b></p> <ol style="list-style-type: none"> <li>1. With the display showing <i>NEXT PHONE TEST nnn DAYS (current setting)</i>, enter the number of days (1–255). The display flashes the entered setting.</li> <li>2. Press # and the display shows the new setting.</li> </ol>

<b>Output Trip Time (0305)</b>	<i>Timers-Global (Default = 4 sec.)</i>
<p>This setting determines how long outputs are activated when tripped (if they are configured for a momentary response).</p>	<p>➤ <b>To set the Output Trip Time:</b></p> <ol style="list-style-type: none"> <li>1. With the display showing <i>OUTPUT TRIP TIME nn SECS (current setting)</i>, enter the number of seconds (1–12). The display flashes the entered setting.</li> <li>2. Press # and the display shows the new setting.</li> </ol>

<b>Activity Timeout (0306)</b>	<i>Timers-Global (Default = 24 hours)</i>
<p>This setting determines when the system sends a “no activity” report. The panel can be set to wait from 1–42 hours. If no user interaction or device activation occurs in that time, the panel sends a report to the central station.</p>	<p>➤ <b>To set the Activity Timeout:</b></p> <ol style="list-style-type: none"> <li>1. With the display showing <i>ACTIVITY TIMEOUT nn HOURS (current setting)</i>, enter the number of hours (1–42). The display flashes the entered setting.</li> <li>2. Press # and the display shows the new setting.</li> </ol>

<b>Daylight Saving (0307)</b>	<i>Timers-Global (Default = on)</i>
<p>When this setting is on, the panel clock automatically adjusts for daylight saving time changes.</p>	<p>➤ <b>To turn Daylight Saving off or on:</b></p> <ol style="list-style-type: none"> <li>1. With the display showing <i>DAYLIGHT SAVING OFF/ON (current setting)</i>, press 1 (off) or 2 (on). The display flashes the entered setting.</li> <li>2. Press # and the display shows the new setting.</li> </ol>

The following sections describe the settings that appear under *PARTITION 1-6*.

<b>Entry Delay (0310 - 0360)</b>	<i>Timers-Partition 1-6 (Default = 30 sec.)</i>
<p>This setting determines how much time the user has to disarm the system (after entering the armed premises through a “designated delay door”) without causing an alarm.</p> <p><b>Note</b> For UL 1023 Listed installations, the Entry Delay must be set to 45 seconds or less. The combined time for the Entry Delay and Dialer Abort Delay (02006) must not exceed 60 seconds.</p>	<p>➤ <b>To set the Entry Delay:</b></p> <ol style="list-style-type: none"><li>1. With the display showing <i>ENTRY DELAY nm SECS (current setting)</i>, enter the desired time value (30–240). The display flashes the entered setting.</li><li>2. Press # and the display shows the new setting.</li></ol>

<b>Exit Delay (0311 - 0361)</b>	<i>Timers-Partition 1-6 (Default = 60 sec.)</i>
<p>This setting determines how much time the user has (after arming the system) to leave the premises through a “designated delay door” without causing an alarm.</p> <p><b>Note</b> For UL 1023 listed installations, this feature must be set to 60 seconds or less. For UL 1610 listed installations, this feature must be set to 120 seconds or less.</p>	<p>➤ <b>To set the Exit Delay:</b></p> <ol style="list-style-type: none"><li>1. With the display showing <i>EXIT DELAY nm SECS (current setting)</i>, enter the desired time value (45–184). The display flashes the entered setting.</li><li>2. Press # and the display shows the new setting.</li></ol>

<b>Extended Delay (0312 - 0362)</b>	<i>Timers-Partition 1-6 (Default = 4 min.)</i>
<p>This setting determines how much time the user has (after arming the system) to enter <i>or</i> exit the premises through a “designated <i>extended</i> delay door” (1–8 minutes).</p> <p><b>Note</b> For UL Listed installations <i>Extended Delay</i> may not be used.</p>	<p>➤ <b>To set the Extended Delay:</b></p> <ol style="list-style-type: none"><li>1. With the display showing <i>EXTENDED DELAY n MINUTES (current setting)</i>, enter the desired time value (1–8). The display flashes the entered setting.</li><li>2. Press # and the display shows the new setting.</li></ol>

<b>Siren Timeout (0313 - 0363)</b>	<i>Timers-Partition 1-6 (Default = 4 min.)</i>
<p>This setting determines how long sirens sound (1–30 minutes) if no one is present to disarm the system.</p> <p><b>Note</b> For UL Listed installations, the Siren Timeout must be set to 4 minutes or more.</p>	<p>➤ <b>To set the Siren Timeout:</b></p> <ol style="list-style-type: none"><li>1. With the display showing <i>SIREN TIMEOUT nm MINUTES (current setting)</i>, enter the desired time value (1–30). The display flashes the entered setting.</li><li>2. Press # and the display show the new setting.</li></ol>

<b>Sleep Time (0314 - 0364)</b>	<i>Timers-Partition 1-6 (Default = 22:00 [10:00 pm])</i>
<p>This setting determines the start time and restart of a 10-hour window during which trouble beeps are suppressed. The initial occurrence of an event that causes trouble beeps within this window will not sound trouble beeps until the Sleep Time window expires. If trouble beeps from a previous event are due to be restarted during the sleep time window, they will be restarted one hour prior to Sleep Time.</p> <p><b>Note</b> For UL listed installations, this feature must be set to off.</p>	<p>➤ <b>To set the Sleep Time:</b></p> <ol style="list-style-type: none"><li>1. With the display showing <i>SLEEP TIME hh:mm (current setting)</i>, enter the desired time value (00:00–23:50 using 10 minute intervals). The display flashes the entered setting.</li><li>2. Press # and the display show the new setting.</li></ol> <p>➤ <b>To turn off Sleep Time:</b></p> <ol style="list-style-type: none"><li>1. With the display showing <i>SLEEP TIME hh:mm (current setting)</i>, press D.</li></ol>

**No Usage Time (0315 - 0365)***Timers-Partition 1-6 (Default = none)*

Determines how many days a partition can remain disarmed before the panel sends a No Usage report to the central monitoring station and stores the event in the history buffer.

When this feature is set:

- This timer decreases by one at STIME each day the selected partition remains disarmed.
- If the timer gets to 0 at STIME, the panel sends a No Usage report to the central monitoring station and stores the event in the history buffer.
- If the partition is armed before the timer reaches 0, the timer resets to the programmed setting.

When this feature is not set (default), the panel does not send or log No Usage reports.

➤ **To set the No Usage Time:**

1. With the display showing *NO USAGE TIME (current setting)*, enter the desired number in days (2-255). The display flashes the entered setting.
2. Press # and the display show the new setting.

➤ **To turn off No Usage Time:**

1. With the display showing *NO USAGE TIME (current setting)*, press D.

**Light Control Menu**

The *LIGHT CONTROL* menu lets you set up light activation for a specific partition.

The following describes how to program the settings that appear under *PARTITION 1-6*.

**Note**

For light control to work, the panel must be powered with a power line carrier transformer and X10 Powerhouse Lamp Modules must be installed at desired lamps.

**Entry Lights (0400 - 0450)***Light Control (Default = none)*

This setting determines which X10 controlled lights turn on during entry and exit delays.

**Note**

X10 Lamp Modules set to 1 always turn on during the entry and exit delays.

X10 Lamp Modules set to 2 always flash the arming level when arming the system. For example, lights flash two times when arming to STAY (level 2), and three times when arming to AWAY (level 3).

➤ **To set the Entry Lights:**

1. With the desired partition selected, press #. The display shows *ENTRY LIGHTS nnnnnn (current setting)*.
2. Enter *all* the desired light numbers (3-9 based on the UNIT dial setting on each X10 Lamp Module). The display flashes the entered setting(s). Press # and the display shows the new setting(s).

➤ **To delete Entry Lights:**

1. Enter any light number that appears on the display, then press #. The number disappears from the display.

**House Code (0401 - 0451)***Light Control (Defaults: partition 1=01-B, partition 2=02-C, partition 3=03-D, partition 4=04-E, partition 5=05-F, partition 6=06-G)*

This setting enables X10 controlled lights to work in a selected partition without interfering with the X10 controlled lights of the other partitions.

After setting the panel house code for each partition, you must set the X10 controlled lights for that partition to the same house code. The letter that appears automatically after the house code number indicates the necessary HOUSE dial setting for X10 modules in that partition.

➤ **To set the House Code:**

1. With the desired partition selected, press A or B until the display shows *HOUSE CODE m-x (current setting)*.
2. Enter the desired number (1-255). The display flashes the entered number. Press # and the display shows the new house code.

## Touchpad Options Menu

The *TOUCHPAD OPTIONS* menu lets you set up touchpad panic and arming operation. The following section describes the settings that appear under *GLOBAL*.

<b>Latchkey Zones (0500)</b>	<i>Touchpad Options-Global (Default = none)</i>
This setting defines the range of keychain touchpads that will function as a latchkey user. The value entered in this section can be any valid zone number. When a zone number is entered, all zones <i>at or below</i> that zone number will function as a latchkey user. For example, if 5 is entered, any keychain touchpads learned into zones 1–5 will be latchkey users and all others (6–96) will not.	<p>➤ <b>To set the number of Latchkey Zones:</b></p> <ol style="list-style-type: none"><li>1. With the display showing <i>LATCHKEY ZONES nnn (current setting)</i>, enter the desired number of latchkey zones (1–96). The display flashes the entered setting.</li><li>2. Press # and the display shows the new setting.</li></ol> <p>➤ <b>To delete/disable Latchkey Zones:</b></p> <ol style="list-style-type: none"><li>1. With the display showing <i>LATCHKEY ZONES nnn (current setting)</i>, press D.</li></ol>

The following sections describe the settings that appear under *PARTITION 1-6*.

<b>Fire Panic (0510 - 0560)</b>	<i>Touchpad Options-Partitions 1-6 (Default = on)</i>
This setting determines whether touchpad fire panic buttons are enabled (on) or disabled (off).	<p>➤ <b>To change the Fire Panic setting:</b></p> <ol style="list-style-type: none"><li>1. With the display showing <i>FIRE PANIC OFF/ON (current setting)</i>, press 1 (off) or 2 (on). The display flashes the entered setting.</li><li>2. Press # and the display shows the new setting.</li></ol>

<b>Aux. Panic (0511 - 0561)</b>	<i>Touchpad Options-Partitions 1-6 (Default = on)</i>
This setting determines whether touchpad auxiliary panic buttons are enabled (on) or disabled (off).	<p>➤ <b>To change the Auxiliary Panic setting:</b></p> <ol style="list-style-type: none"><li>1. With the display showing <i>AUXILIARY PANIC OFF/ON (current setting)</i>, press 1 (off) or 2 (on). The display flashes the entered setting.</li><li>2. Press # and the display shows the new setting.</li></ol>

<b>Police Panic (0512 - 0562)</b>	<i>Touchpad Options-Partitions 1-6 (Default = on)</i>
This setting determines whether touchpad police panic buttons are enabled (on) or disabled (off).	<p>➤ <b>To change the Police Panic setting:</b></p> <ol style="list-style-type: none"><li>1. With the display showing <i>POLICE PANIC OFF/ON (current setting)</i>, press 1 (off) or 2 (on). The display flashes the entered setting.</li><li>2. Press # and the display shows the new setting.</li></ol>

<b>Keychain TP Arm (0513 - 0563)</b>	<i>Touchpad Options-Partitions 1-6 (Default = off)</i>
<p>When this setting is on, pressing the lock button on keychain touchpads arms the system directly to AWAY with NO DELAY.</p> <p>When this setting is off, each key-press increments the arming level (i.e., from OFF to STAY, from STAY to AWAY).</p>	<p>➤ <b>To change the Keychain Touchpad Arming setting:</b></p> <ol style="list-style-type: none"><li>1. With the display showing <i>KEYCHAIN TP ARM OFF/ON (current setting)</i>, press 1 (off) or 2 (on). The display flashes the entered setting.</li><li>2. Press # and the display shows the new setting.</li></ol>



<b>Star Is No Delay (0514 - 0564)</b>	<i>Touchpad Options-Partitions 1-6 (Default = off)</i>
<p>This setting determines whether the keychain touchpad star button controls an output (off) or the No Delay feature (on).</p>	<p>➤ <b>To change the keychain Star Is No Delay setting:</b></p> <ol style="list-style-type: none"> <li>1. With the display showing <i>STAR IS NO DELAY OFF/ON (current setting)</i>, press 1 (off) or 2 (on). The display flashes the entered setting.</li> <li>2. Press # and the display shows the new setting.</li> </ol>

### **Reporting Menu**

The *REPORTING* menu lets you set up which system events are reported to the central monitoring station. The following describes how to program the settings that appear under *GLOBAL*.

<b>24-Hour Tamper (06000)</b>	<i>Reporting-Global (Default = off)</i>
<p><b>Note</b> <i>Tamper conditions for fire sensors (group 26) always cause trouble beeps to sound and report the tamper condition to the central station, regardless of this feature setting.</i></p> <p>When turned on, the panel sounds sirens and reports a tamper alarm (even when the system is disarmed), when non-fire wireless sensor tamper switches are activated.</p> <p>When turned off, the panel sounds sirens and reports a tamper alarm only when non-fire wireless sensor tamper switches are activated and those sensors are active for the current arming level. For non-fire sensors not active in the current arming level that have their tamper switch activated, trouble beeps sound and the panel sends a sensor tamper report to the central station if the System Tamper feature is on for that partition.</p> <p><b>Note</b> <i>For commercial UL Listed installations (UL 1610) the 24-Hour Tamper must be set to on.</i></p>	<p>➤ <b>To turn 24-Hour Tamper off or on:</b></p> <ol style="list-style-type: none"> <li>1. With the display showing <i>24 HOUR TAMPER OFF/ON (current setting)</i>, press 1 (off) or 2 (on). The display flashes the entered setting.</li> <li>2. Press # and the display shows the new setting.</li> </ol>

<b>Antenna Tamper (06001)</b>	<i>Reporting-Global (Default = off)</i>
<p>Determines whether the panel monitors for antenna tamper of onboard and all connected bus transceivers and receivers.</p> <p>When turned on, the panel sounds trouble beeps in all partitions and reports an antenna tamper condition. Touchpads in all partitions show a receiver tamper trouble condition.</p> <p>When turned off, the panel ignores antenna tampers.</p> <p><b>Note</b> <i>If the system includes SuperBus 2000 RF Receivers, this setting must be off.</i></p>	<p>➤ <b>To turn Antenna Tamper off or on:</b></p> <ol style="list-style-type: none"> <li>1. With the display showing <i>ANTENNA TAMPER OFF/ON (current setting)</i>, press 1 (off) or 2 (on). The display flashes the entered setting.</li> <li>2. Press # and the display shows the new setting.</li> </ol>

<b>Buffer Control (06002)</b>	<i>Reporting-Global (Default = off)</i>
<p>When this setting is on, only arming level changes and time changes (system time and daylight savings time) are logged in the buffer (memory) of the panel. When this setting is off, all system events are logged in the buffer.</p>	<p>➤ <b>To turn Buffer Control off or on:</b></p> <ol style="list-style-type: none"> <li>1. With the display showing <i>BUFFER CONTROL OFF/ON (current setting)</i>, press 1 (off) or 2 (on). The display flashes the entered setting.</li> <li>2. Press # and the display shows the new setting.</li> </ol>

<b>Back In Service (06003)</b>	<i>Reporting-Global (Default = on)</i>
When this setting is on, the panel reports to the central station when AC and backup battery power are restored (after an extended power outage).	<p>➤ <b>To turn Back In Service reports off or on:</b></p> <ol style="list-style-type: none"> <li>1. With the display showing <i>BACK IN SERVICE OFF/ON (current setting)</i>, press 1 (off) or 2 (on). The display flashes the entered setting.</li> <li>2. Press # and the display shows the new setting.</li> </ol>

<b>Bypass Reports (06004)</b>	<i>Reporting-Global (Default = off)</i>
When this setting is on, the panel reports to the central station whenever sensors or zones are bypassed.	<p>➤ <b>To turn Bypass Reports off or on:</b></p> <ol style="list-style-type: none"> <li>1. With the display showing <i>BYPASS REPORTS OFF/ON (current setting)</i>, press 1 (off) or 2 (on). The display flashes the entered setting.</li> <li>2. Press # and the display shows the new setting.</li> </ol>

<b>Low CPU Battery (06005)</b>	<i>Reporting-Global (Default = on)</i>
When turned on, the panel reports a low panel battery to the central station when the system battery test fails. <i>If this feature and the Aux Power Fail feature are both on, the panel also monitors for and reports a low battery for the SuperBus 2000 2-Amp Power Supply.</i>	<p>➤ <b>To turn Low CPU Battery reports off or on:</b></p> <ol style="list-style-type: none"> <li>1. With the display showing <i>LOW CPU BATTERY OFF/ON (current setting)</i>, press 1 (off) or 2 (on). The display flashes the entered setting.</li> <li>2. Press # and the display shows the new setting.</li> </ol>
<p><b>Note</b> For UL 1635 listed installations, the Low CPU Battery feature must be set to on.</p>	

<b>Battery Restoral (06006)</b>	<i>Reporting-Global (Default = off)</i>
If this setting is on, the panel reports to the central monitoring station when a wireless sensor or touchpad reports a battery replacement to the panel.	<p>➤ <b>To turn Battery Restoral reports off or on:</b></p> <ol style="list-style-type: none"> <li>1. With the display showing <i>BATTERY RESTORAL OFF/ON (current setting)</i>, press 1 (off) or 2 (on). The display flashes the entered setting.</li> <li>2. Press # and the display shows the new setting.</li> </ol>

<b>Buffer Full Rpt (06007)</b>	<i>Reporting-Global (Default = off)</i>
When this setting is on, the panel sends an “event buffer full” report to the central monitoring station when the event buffer is nearing full. When turned off, no report is sent.	<p>➤ <b>To turn Buffer Full Report off or on:</b></p> <ol style="list-style-type: none"> <li>1. With the display showing <i>BUFFER FULL RPT OFF/ON (current setting)</i>, press 1 (off) or 2 (on). The display flashes the entered setting.</li> <li>2. Press # and the display shows the new setting.</li> </ol>

<b>Zone Restorals (06008)</b>	<i>Reporting-Global (Default = off)</i>
When this setting is on, the panel reports a restoral to the central monitoring station for wireless or hardwire zones in alarm before the alarm is canceled.	<p>➤ <b>To turn Zone Restoral reporting off or on:</b></p> <ol style="list-style-type: none"> <li>1. With the display showing <i>ZONE RESTORALS OFF/ON (current setting)</i>, press 1 (off) or 2 (on). The display flashes the entered setting.</li> <li>2. Press # and the display shows the new setting.</li> </ol>
<p><b>Note</b> As with all GE Security panels, hardwire smoke detectors connected to panel or SnapCard hardwire zones do not send restorals.</p>	

<b>Two Trip Error (06009)</b>	<i>Reporting-Global (Default = off)</i>
<p>This setting works with the Alarm Verify setting (see “Alarm Verify” later in this section and Appendix B: Table B1 “Sensor Table Characteristics”). If Alarm Verify is on, then the panel waits for a second sensor trip before sending an alarm.</p> <p><b>Note</b> For UL Listed installations, the Two Trip Error feature must be set to off.</p> <p>If Two Trip Error is also on and a second sensor trip <i>does not occur</i> within a 4-minute time period, then the panel sends an error report to the central monitoring station.</p>	<p>➤ <b>To turn Two Trip Error off or on:</b></p> <ol style="list-style-type: none"> <li>1. With the display showing <i>TWO TRIP ERROR OFF/ON (current setting)</i>, press 1 (off) or 2 (on). The display flashes the entered setting.</li> <li>2. Press # and the display shows the new setting.</li> </ol>

<b>TP Panic RPT FMT (06010)</b>	<i>Reporting-Global (Default = off)</i>
<p>This setting determines how the panel formats touchpad panic alarm reports to the central station.</p> <p>When this feature is turned on, touchpad panic alarms report using the following 3-digit codes: Auxiliary—597, Police—598, Fire—599</p> <p>When turned off, touchpad panic alarms report using a 3-digit code from 500 to 515, with the last 2 digits identifying the touchpad device number.</p>	<p>➤ <b>To turn TP Panic RPT FMT off or on:</b></p> <ol style="list-style-type: none"> <li>1. With the display showing <i>TP PANIC RPT FMT OFF/ON (current setting)</i>, press 1 (off) or 2 (on). The display flashes the entered setting.</li> <li>2. Press # and the display shows the new setting.</li> </ol>

<b>AC Failure (06011)</b>	<i>Reporting-Global (Default = off)</i>
<p>When this setting is on, the panel reports to the central station at a random time between 15 and 45 minutes after AC power to the panel is lost. Making the report random helps prevent systems in a power outage affected area from trying to report at the same time.</p> <p><b>Note</b> If this feature and the Aux Power Fail feature are both on, the panel also monitors for and reports an AC failure for the SuperBus 2000 2-Amp Power Supply.</p> <p><b>Note</b> For UL Listed installations, AC Failure must be set to on.</p>	<p>➤ <b>To turn AC Failure reports off or on:</b></p> <ol style="list-style-type: none"> <li>1. With the display showing <i>AC FAILURE OFF/ON (current setting)</i>, press 1 (off) or 2 (on). The display flashes the entered setting.</li> <li>2. Press # and the display shows the new setting.</li> </ol>

<b>Receiver Failure (06012)</b>	<i>Reporting-Global (Default = off)</i>
<p>When this setting is on, the panel reports a receiver failure under the following conditions:</p> <ul style="list-style-type: none"> <li>• No wireless sensor signals have been received for two hours or</li> <li>• The receiver is being jammed with a constant signal.</li> </ul> <p><b>Note</b> For UL Listed installations using wireless devices, Receiver Failure must be set to on.</p>	<p>➤ <b>To turn Receiver Failure reports off or on:</b></p> <ol style="list-style-type: none"> <li>1. With the display showing <i>RECEIVER FAILURE OFF/ON (current setting)</i>, press 1 (off) or 2 (on). The display flashes the entered setting.</li> <li>2. Press # and the display shows the new setting.</li> </ol>

<b>RF Low Bat Rpt (06013)</b>	<i>Reporting-Global (Default = weekly)</i>
<p>This setting determines whether the panel sends daily or weekly low battery reports to the central monitoring station when a wireless device is reporting a low battery condition to the panel.</p>	<p>➤ <b>To set RF Low Battery Report to daily or weekly:</b></p> <ol style="list-style-type: none"> <li>1. With the display showing <i>RF LOW BAT RPT DAILY/WEEKLY (current setting)</i>, press 1 (daily) or 2 (weekly). The display flashes the entered setting.</li> <li>2. Press # and the display shows the new setting.</li> </ol>

<b>RF Supv Report (06014)</b>	<i>Reporting-Global (Default = weekly)</i>
<p>This setting determines whether the panel sends daily or weekly reports to the central monitoring station when the panel detects a supervisory condition in a wireless device.</p>	<p>➤ <b>To set RF Supv Report to daily or weekly:</b></p> <ol style="list-style-type: none"> <li>1. With the display showing <i>RF SUPV REPORT DAILY/ WEEKLY (current setting)</i>, press 1 (daily) or 2 (weekly). The display flashes the entered setting.</li> <li>2. Press # and the display shows the new setting.</li> </ol>

<b>Swinger Limit (06015)</b>	<i>Reporting-Global (Default = 1)</i>
<p>This setting determines the maximum number of times (1–2) a sensor or zone can go into alarm (during a single arming period) before the panel automatically bypasses that sensor or zone. This feature only applies to sensors or zones in groups 00–20, 29, 34, 35, or 38.</p> <p>When set to 1, the panel automatically bypasses a sensor or zone after it causes an alarm. When set to 2, the panel waits until a sensor or zone has caused a second alarm (during the same arming period) before bypassing it. At any setting, the automatic bypass is logged into the event buffer.</p> <p>A bypassed sensor or zone will be cleared (automatically unbypassed) if the system receives no further activations from that sensor or zone over the next 48–50 hours.</p> <p>Changing the arming level also clears all automatically bypassed sensors and zones and resets the Swinger Limit count on all sensors and zones.</p>	<p>➤ <b>To set the Swinger Limit:</b></p> <ol style="list-style-type: none"> <li>1. With the display showing <i>SWINGER LIMIT n (current setting)</i>, press the desired number (1–2). The display flashes the entered setting.</li> <li>2. Press # and the display shows the new setting.</li> </ol>

<b>Aux Power Fail (06016)</b>	<i>Reporting-Global (Default = on)</i>
<p>When this setting is on, the panel sends a report to the central monitoring station if the 12 VDC power outputs on the panel and/or SuperBus 2000 2-Amp Power Supply fail.</p> <p><b>Note</b> If this feature is on and the AC Failure and Low CPU Battery features are both on, the panel sends AC failure and low backup battery reports for the SuperBus 2000 2-Amp Power Supply.</p>	<p>➤ <b>To turn Program Report on or off:</b></p> <ol style="list-style-type: none"> <li>1. With the display showing <i>AUX POWER FAIL ON/OFF (current setting)</i>, press 1 (off) or 2 (on). The display flashes the entered setting.</li> <li>2. Press # and the display shows the new setting.</li> </ol>

<b>Ground Fault (06017)</b>	<i>Reporting-Global (Default = on)</i>
<p>When this setting is ON, the panel will annunciate and send a report to the central monitoring station if it detects current flow between the panel's circuitry and the chassis. This indicates that a short to earth ground exists somewhere in the system.</p> <p><b>Note</b> This feature must be on if hardware smoke sensors are used in this system.</p>	<p>➤ <b>To turn Ground Fault on or off:</b></p> <ol style="list-style-type: none"> <li>1. With the display showing <i>GROUND FAULT OFF/ ON (current setting)</i>, press 1 (off) or 2 (on).</li> <li>2. Press # and the display shows the new setting.</li> </ol>

The following describes the settings that appear under *REPORTING—PARTITION 1-6*.

<b>Opening Reports (06100 - 06600)</b>	<i>Reporting-Partition 1-6 (Default = off)</i>
<p>When this setting is on, the panel sends an opening report to the central station after disarming the system.</p> <p><b>Note</b> To use this feature, the Open/Close Reports settings under the PHONES menu must be turned on for the specific CS Phone or Pager number.</p>	<p>➤ <b>To turn Opening Reports off or on:</b></p> <ol style="list-style-type: none"> <li>1. With the display showing <i>OPENING REPORTS OFF/ON (current setting)</i>, press 1 (off) or 2 (on). The display flashes the entered setting.</li> <li>2. Press # and the display shows the new setting.</li> </ol>

<b>Closing Reports (06101 - 06601)</b>	<i>Reporting-Partition 1-6 (Default = off)</i>
<p>When this setting is on, the panel sends a closing report to the central station after arming the system.</p> <p><b>Note</b> To use this feature, the Open/Close Reports settings under the PHONES menu must be turned on for the specific CS Phone or Pager number.</p>	<p>➤ <b>To turn Closing Reports off or on:</b></p> <ol style="list-style-type: none"> <li>1. With the display showing <i>CLOSING REPORTS OFF/ON (current setting)</i>, press 1 (off) or 2 (on). The display flashes the entered setting.</li> <li>2. Press # and the display shows the new setting.</li> </ol>

<b>No Activity (06102 - 06602)</b>	<i>Reporting-Partition 1-6 (Default = off)</i>
<p>When this setting is on, the panel sends a no activity report to the central station when the activity timeout expires (see <i>TIMERS—ACTIVITY TIMEOUT</i>).</p>	<p>➤ <b>To turn No Activity reports off or on:</b></p> <ol style="list-style-type: none"> <li>1. With the display showing <i>NO ACTIVITY OFF/ON (current setting)</i>, press 1 (off) or 2 (on). The display flashes the entered setting.</li> <li>2. Press # and the display shows the new setting.</li> </ol>

<b>Duress Option (06103 - 06603)</b>	<i>Reporting-Partition 1-6 (Default = off)</i>
<p>(Default = off) When this setting is on, the system can be controlled using a programmed duress code (see <i>SECURITY—PARTITION N—DURESS CODE</i>) and will send a duress alarm to the monitoring station.</p> <p><b>Note</b> For UL Listed installations, Duress Option must be set to off.</p> <p>Do not use a duress code unless it is absolutely necessary. Using duress codes often results in false alarms due to code entry errors. If a duress code <i>is</i> absolutely necessary, use it with the audio verification module to reduce false alarms and accidental dispatches.</p>	<p>➤ <b>To turn Duress Option off or on:</b></p> <ol style="list-style-type: none"> <li>1. With the display showing <i>DURESS OFF/ON (current setting)</i>, press 1 (off) or 2 (on). The display flashes the entered setting.</li> <li>2. Press # and the display shows the new setting.</li> </ol>

<b>Force Armed (06104 - 06604)</b>	<i>Reporting-Partition 1-6 (Default = off)</i>
<p>When this setting is on, the panel reports to the central monitoring station when a user “force arms” the system.</p> <p><b>Note</b> Forced arming occurs if the user presses <i>BYPASS</i> when arming the system with open sensors/zones protesting.</p> <p>Auto-forced arming occurs when the user does not press <i>BYPASS</i> when arming the system with open sensors/zones protesting, then leaves through an entry/exit door and the arming protest period expires. This causes the system to automatically bypass the open (protesting) sensors.</p> <p>Auto-forced arming always reports to the central monitoring station.</p> <p>Auto-forced arming has not been investigated by UL.</p>	<p>➤ <b>To turn Force Armed off or on:</b></p> <ol style="list-style-type: none"> <li>1. With the display showing <i>FORCE ARMED OFF/ON (current setting)</i>, press 1 (off) or 2 (on). The display flashes the entered setting.</li> <li>2. Press # and the display shows the new setting.</li> </ol>

**Latchkey Format (06105 - 06605)**

Reporting-Partition 1-6 (Default = off)

(Default = off) This setting determines whether the selected partition is set up for basic (off) or advanced (on) latchkey opening report operation.

**Basic:**

If the partition is armed by entering 2 (or 3) + CODE, *disarming using a designated latchkey user code or keychain touchpad within an assigned time schedule* sends a page.

Arming the partition by entering 2 (or 3) + CODE + 6 (Latchkey) sends a page.

If the partition is armed by entering 2 (or 3) + CODE + 6 (Latchkey), *disarming using a designated latchkey user code or keychain touchpad inside or outside of an assigned time schedule* sends a page.

**Advanced:**

Arming the partition by entering 2 (or 3) + CODE + 6 (Latchkey) within an assigned time schedule sends a page.

If the partition is armed by entering 2 (or 3) + CODE + 6 (Latchkey), *disarming using a latchkey designated user code or keychain touchpad within an assigned time schedule* sends a page.

Refer to the *User's Guide* for complete Latchkey setup and operation.

➤ **To turn Latchkey Format off or on:**

1. With the desired partition selected, press A or B until the display shows *LATCHKEY FORMAT OFF/ON (current setting)*.
2. Press 1 (off—basic) or 2 (on—advanced). The display flashes the entered setting. Press # and the display shows the new setting.

**Freeze Alarm (06106 - 06606)**

Reporting-Partition 1-6 (Default = off)

This setting determines whether the panel reports a freeze alarm to the central station or pager, when the selected partition's energy saver module detects a temperature that matches a predetermined setting (see *BUS DEVICES—UNIT ID—ENERGY OPTIONS—FREEZE TEMP*, or *FREEZE TEMP* below).

➤ **To turn Freeze Alarm reporting off or on:**

1. With the desired partition selected, press A or B until the display shows *FREEZE ALARM OFF/ON (current setting)*.
2. Press 1 (off) or 2 (on). The display flashes the entered setting. Press # and the display shows the new setting.

**Freeze Temp (06107 - 06607)**

Reporting-Partition 1-6 (Default = 42°F)

This setting determines the temperature point the Energy Saver Module detects a potential freeze (heating failure) condition. The adjustable range is from 40° - 90° F.

**Note**

*This is the same menu found under ACCESSORY MODULES/BUS DEVICES/UNIT ID/ENERGY OPTIONS.*

➤ **To set the Freeze Temp:**

1. With the desired partition selected, press A or B until the display shows *FREEZE TEMP (current setting)*.
2. Enter the desired temperature (40-90). The display flashes the entered setting. Press # and the display shows the new setting.

**Alarm Verify (06108 - 06608)**

Reporting-Partition 1-6 (Default = off)

This setting determines whether the panel reports to the central monitoring station after a single sensor or zone trip (off) or waits for a second trip before reporting (on).

This setting affects sensors/zones in groups 10 through 20. If Alarm Verify is set to on, group 18 responds the same as group 17 (see "Appendix B, Table B1 "Sensor Group Characteristics").

**Note**

*For UL Listed installations, Alarm Verify must be set to off.*

➤ **To turn Alarm Verify off or on:**

1. With the display showing *ALARM VERIFY OFF/ON (current setting)*, press 1 (off) or 2 (on). The display flashes the entered setting.
2. Press # and the display shows the new setting.

<b>System Tamper (06109 - 06609)</b>	<i>Reporting-Partition 1-6 (Default = off)</i>
<p>This setting determines how the panel handles possible tamper situations. When this feature is on, the panel reacts as follows:</p> <ul style="list-style-type: none"> <li>• Initiates an alarm when the system prompts for an access code (arming/disarming, etc.) and several wrong access codes are entered (40 consecutive invalid keypresses).</li> <li>• Reports to the central station if a bus device stops communicating with the panel.</li> <li>• Reports to the central monitoring station if a tamper condition occurs on unarmed RF (wireless) devices.</li> </ul> <p><b>Note</b> For UL Commercial Listed installations (UL 1610), System Tamper must be set to on.</p>	<p>➤ <b>To change the System Tamper setting:</b></p> <ol style="list-style-type: none"> <li>1. With the display showing <i>SYSTEM TAMPER OFF/ON (current setting)</i>, press 1 (off) or 2 (on). The display flashes the entered setting.</li> <li>2. Press # and the display shows the new setting.</li> </ol>

<b>Report Confirm (06111 - 06611)</b>	<i>Reporting-Partition 1-6 (Default = off)</i>
<p>When this setting is on, system status speakers announce “Report is okay” followed by a single beep each time a successful report is made to the central monitoring station. When turned off, no status message or beep sounds.</p>	<p>➤ <b>To change the Report Confirm setting:</b></p> <ol style="list-style-type: none"> <li>1. With the display showing <i>REPORT CONFIRM OFF/ON (current setting)</i>, press 1 (off) or 2 (on). The display flashes the entered setting.</li> <li>2. Press # and the display shows the new setting.</li> </ol>

### **Siren Options Menu**

The *SIREN OPTIONS* menu lets you set up siren operation and supervision.

The following describes how to program the settings that appear under *GLOBAL*.

<b>Immediate Beeps (0700)</b>	<i>Siren Options-Global (Default = off)</i>
<p>This setting determines whether the panel activates trouble beeps as soon as a wireless device supervisory condition is detected (on), or if the panel waits 10 hours after the supervisory condition is detected to activate trouble beeps (off). (Refer to <i>TIMERS—GLOBAL—SUPERVISORY TIME</i>).</p> <p><b>Note</b> For UL Listed installations, this feature must be on.</p>	<p>➤ <b>To turn Immediate Beeps off or on:</b></p> <ol style="list-style-type: none"> <li>1. With the display showing <i>IMMEDIATE BEEPS OFF/ON (current setting)</i>, press 1 (off) or 2 (on). The display flashes the entered setting.</li> <li>2. Press # and the display shows the new setting.</li> </ol>

<b>Disable Trouble Beeps (0701)</b>	<i>Siren Options-Global (Default = off)</i>
<p>When turned on, the panel does not initiate beeps to alert users of non-fire wireless device supervisory trouble and does not protest on arming if the condition exists.</p> <p><b>Note</b> If <i>Immediate Beeps</i> is set to on, trouble beeps sound for supervisory trouble conditions regardless of this menu setting.</p> <p><b>Note</b> For UL Listed installations, <i>Disable Trouble Beeps</i> must be set to off.</p>	<p>➤ <b>To turn Disable Trouble Beeps off or on:</b></p> <ol style="list-style-type: none"> <li>1. With the display showing <i>DISABLE TR BEEPS OFF/ON (current setting)</i>, press 1 (off) or 2 (on). The display flashes the entered setting.</li> <li>2. Press # and the display shows the new setting.</li> </ol>

<b>UL 98 Options (0702)</b>	<i>Siren Options-Global (Default = off)</i>
<p>This setting determines whether the panel complies with UL 98 requirements (4-hour trouble beep restart, 4-hour backup battery test, 4-hour smoke (group 26) zone supervisory).</p> <p><b>Note</b> For UL Listed installations, this feature must be on.</p>	<p>➤ <b>To turn UL 98 Options off or on:</b></p> <ol style="list-style-type: none"> <li>1. With the display showing <i>UL 98 OPTIONS OFF/ON (current setting)</i>, press 1 (off) or 2 (on). The display flashes the entered setting.</li> <li>2. Press # and the display shows the new setting.</li> </ol>

<b>Global Fire (0703)</b>	<i>Siren Options-Global (Default = off)</i>
<p>This setting determines whether or not sirens in all partitions sound (on) if any partition activates a fire alarm.</p>	<p>➤ <b>To turn Global Fire off or on:</b></p> <ol style="list-style-type: none"> <li>1. With the display showing <i>GLOBAL FIRE OFF/ON (current setting)</i>, press 1 (off) or 2 (on). The display flashes the entered setting.</li> <li>2. Press # and the display shows the new setting.</li> </ol>

<b>Silent Panic (0704)</b>	<i>Siren Options-Global (Default = off)</i>
<p>This setting determines whether touchpad police panic alarms are audible (off) or silent (on).</p>	<p>➤ <b>To turn Silent Panic off or on:</b></p> <ol style="list-style-type: none"> <li>1. With the display showing <i>GLOBAL SILENT PANIC OFF/ON (current setting)</i>, press 1 (off) or 2 (on). The display flashes the entered setting.</li> <li>2. Press # and the display shows the new setting.</li> </ol>

The following describes the settings that appear under *SIREN OPTIONS—PARTITION 1*.

<b>Siren Verify (0710)</b>	<i>Siren Options-Partition 1 (Default = off)</i>
<p>This setting determines whether or not the panel supervises the panel speaker terminals (7–8). When this feature is on, the panel will indicate a trouble condition if no speaker is connected to panel speaker terminals.</p> <p><b>Note</b> For UL Listed installations, Siren Verify must be set to on.</p>	<p>➤ <b>To turn Siren Verify off or on:</b></p> <ol style="list-style-type: none"> <li>1. With the display showing <i>SIREN VERIFY OFF/ON (current setting)</i>, press 1 (off) or 2 (on). The display flashes the entered setting.</li> <li>2. Press # and the display shows the new setting.</li> </ol>

### Sensors Menu

The *SENSORS* menu gives you access to the following settings:

- *LEARN SENSORS* lets you add (learn) hardwire zones, wireless sensors, and wireless touchpads into panel memory.
- *SENSOR TEXT* lets you “name” the sensors and zones you have added to the system.
- *DELETE SENSORS* lets you delete zones and sensors from panel memory.
- *EDIT SENSORS* lets you view and, if desired, change a sensor group or partition assignment. You can also identify whether a zone is wireless or hardwire, whether it is configured as Normally Closed (N/C) or Normally Open (N/O), or if the zone is a touchpad.

**Table 6: How to Trip Sensors**

<b>Sensor</b>	<b>Steps to Trip Sensor</b>
Hardwire Zones	Start with the zone in its “normal” state, then trip the zone into its alarm state. A normally closed door, for example, should be closed when you begin the Learn Sensors process. To trip the zone, open the door.
Wireless Sensors	Follow the instructions included with each sensor.



**Table 6: How to Trip Sensors**

Sensor	Steps to Trip Sensor
Wireless Door/Window Sensors with External Contacts	Place the external contact in the alarm condition, then activate the sensor tamper switch.
Self Actuated Bell	Activate the tamper switch.
Handheld Wireless Touchpads	Press the BYPASS button.
Keychain Touchpads	Press and hold the lock and unlock buttons together until the touchpad LED flashes.
ELM Keychain Touchpads	<ol style="list-style-type: none"> <li>1. Press and release the unlock button twice quickly, then press and hold until the LED flashes three times.</li> <li>2. Press and release the unlock button once quickly, then press and hold until the LED flashes two times.</li> <li>3. Press and hold the unlock button until the LED flashes once.</li> </ol>

The following describes how to program the sensor settings that appear under LEARN SENSORS.

<b>Learn Sensors (080)</b>	<b>Sensors (Default = none)</b>
<p>The following describes how to add (learn) hardwire zones and wireless devices into panel memory.</p> <p><b>Note</b>  <i>The panel comes with factory programmed onboard hardwire zones. Install 2k-ohm, end of line (EOL) resistors on all unused factory programmed onboard hardwire zones. If you don't want to install EOL resistors, delete any unused zones from memory. See Table 7 for onboard hardwire zone factory programming.</i></p> <p><i>Sensors must be placed in a partition or sensor group. To change the sensor group or partition assignment after adding a sensor or zone, use the EDIT SENSORS menu.</i></p>	<p>➤ <b>To Learn Sensors into panel memory:</b></p> <ol style="list-style-type: none"> <li>1. With the display showing <i>SENSORS</i>, press # and the display shows <i>LEARN SENSORS</i>.</li> <li>2. Press # and the display shows <i>SENSOR PTN 1</i>.</li> <li>3. Press # to select partition 1 or press 2, 3, 4, 5, or 6 + # to select the desired partition. The display should show <i>SENSOR GROUP 0</i>.</li> <li>4. Enter the desired sensor group + # (see Table B1 in “Appendix B” for a description of all sensor group characteristics). The display shows <i>TRIP SENSOR nn</i>, where nn is the displayed (next available) sensor number.</li> <li>5. To change the displayed sensor number, enter the desired sensor number + #. The desired sensor number is displayed.</li> <li>6. With the desired sensor number displayed, use the guidelines in Table 6 to force the sensor or zone you are adding (learning) into the panel memory to send a signal to the panel.</li> <li>7. To add another sensor to the same sensor group and partition, go back to step 5.</li> <li>8. To add sensors to another sensor group or partition, press * twice and go back to step 1 (<i>LEARN SENSORS</i>).</li> </ol>

**Table 7: Onboard Hardwire Zone Factory Programming**

Zone Input	Group No. & Description
1	10–Entry/Exit
2	17–Instant Interior Follower
3	13–Instant Perimeter
4	13–Instant Perimeter
5	13–Instant Perimeter
6	13–Instant Perimeter

**Table 7: Onboard Hardwire Zone Factory Programming**

Zone Input	Group No. & Description
7	13—Instant Perimeter
8	13—Instant Perimeter
<b>Note</b> If the panel memory is cleared, all onboard hardwire zone factory programming will be erased.	

<b>Sensor Text (081)</b>	<b>Sensors (Default = none)</b>
<p>Use the following guidelines to “name” zone and sensor locations:</p> <ul style="list-style-type: none"> <li>• Use the item numbers that appear in Appendix B, Table B2 “Item Numbers and Sensor Text” for characters and words listed there.</li> <li>• If a desired word does not appear in Table B2, create it using the characters (custom text).</li> <li>• When using words from Table B2, spaces between them appear automatically. When using characters from Table B2 to create words, you must reserve an item number for a ‘space’ after the word.</li> <li>• Each character or word uses up one item number. For example, a word from the list counts as one item number. A created word (such as BOY’S) counts as six item numbers—4 letters, 1 apostrophe, and 1 space.</li> <li>• Only 16 item numbers are allowed for each zone or sensor name, so plan ahead before programming sensor text. You may need to abbreviate words to avoid running out of item numbers.</li> </ul>	<p>➤ <b>To program Sensor Text:</b></p> <ol style="list-style-type: none"> <li>1. Press A or B until the display shows <i>SENSOR TEXT</i>.</li> <li>2. Press # and the display shows <i>TEXT FOR SN 01</i>.</li> <li>3. Press A or B until the display shows the desired sensor number (or enter the desired sensor number and press #).</li> <li>4. Press # and the display shows: <i>SN 1 ITEM 0 0 - _____</i>. Where <i>ITEM 0</i> is the first character/word location and <i>0</i> is the character/word number.</li> <li>5. Enter the number of the desired character or word, or scroll through the numbers by pressing B (forward) or A (backward). If you make a mistake, simply enter the correct number or continue scrolling through choices.</li> <li>6. Press # to accept the displayed choice and the display shows: <i>SN 1 ITEM 1 0 -</i>.</li> <li>7. Repeat steps 5 and 6 as needed to complete the zone or sensor name.</li> <li>8. Press * after entering the last character or word number. The display shows the complete text name. For example: <i>TEXT FOR SN 01 FRONT ENTRY DOOR</i></li> </ol>

<b>Delete Sensors (082)</b>	<b>Sensors (Default = none)</b>
<p>The following procedure describes how to remove hardwire zone and wireless sensor numbers from panel memory.</p> <p><b>Note</b> Deleting sensors does not delete sensor text associated with the deleted sensor number. To delete sensor text, enter the <i>SENSOR TEXT</i> menu and enter 000 (nulls) for each item number.</p>	<p>➤ <b>To Delete Sensors from panel memory:</b></p> <ol style="list-style-type: none"> <li>1. Press A or B until the display shows <i>DELETE SENSORS</i>.</li> <li>2. Press # and the display shows <i>DELETE SENSOR nm (lowest zone/sensor number in panel memory)</i>.</li> <li>3. Press # to delete the displayed sensor or—enter the desired sensor number, then press #.</li> <li>4. Repeat steps 2 and 3 until all desired sensors are deleted.</li> </ol>

<b>Edit Sensors (083)</b>	<b>Sensors (Default = none)</b>
<p>This menu lets you view and, if desired, change the group and partition assignment for each learned zone or sensor. For example, the display shows: <i>S01 P1 G13 NC HW BACK DOOR</i>. Where: <i>S01</i> = zone/sensor number, <i>P1</i> = partition 1, <i>G13</i> = sensor group 13, <i>NC</i> = normally closed, <i>HW</i> = hardwired, and <i>BACK DOOR</i> is the programmed text name.</p> <p>Other description codes include, <i>RF</i> = wireless sensor, <i>TP</i> = touchpad, <i>NO</i> = normally open.</p>	<p>➤ <b>To Edit Sensors:</b></p> <ol style="list-style-type: none"> <li>1. Press A or B until the display shows <i>EDIT SENSORS</i>.</li> <li>2. Press # and the display shows the sensor or zone with the lowest number.</li> <li>3. Press A or B to scroll through all learned zones and sensors.</li> <li>4. When the desired zone or sensor is displayed, press #. The display shows <i>SENSOR PTN n (current partition assignment)</i>.</li> <li>5. Enter the desired partition number, then press #. The display shows the new partition assignment.</li> <li>6. Press A or B and the display shows <i>SENSOR GROUP nm (current group assignment)</i>.</li> <li>7. Enter the desired group number, then press #. The display shows the new group assignment.</li> </ol>

## Audio Verification Menu

The *AUDIO VERIFICATION* menu lets you set up the audio verification module (AVM) operation in partition 1. If you want audio verification for partitions 2-6, you must install a “stand-alone” audio verification module and a 4-Relay Output Module (HOM) (60-770) output for that partition.

The following describes the Audio Verification settings that appear under *PARTITION 1*.

<b>Audio Verify (09000)</b>	<i>Audio Verification-Partition 1 (Default = off)</i>
This setting determines whether or not the system can be accessed by phone for alarm verification.	<p>➤ <b>To turn Audio Verification off or on:</b></p> <ol style="list-style-type: none"><li>1. With the display showing <i>AUDIO VERIFICATION</i>, press #. The display shows <i>PARTITION 1</i>.</li><li>2. Press # again and the display shows <i>AUDIO VERIFY OFF/ON (current setting)</i>.</li><li>3. Press 1 (off) or 2 (on). The display flashes the entered setting. Press # and the display shows the new setting.</li></ol>

<b>Audio Mode (09001)</b>	<i>Audio Verification-Partition 1 (Default = 1)</i>
This setting determines how the audio verification module operates. Choose one of the following: <ul style="list-style-type: none"><li>• <b>(1) Instant</b>—Allows the central station operator instant access for an audio session by entering the AVM code or by pressing * (if an AVM access code is not programmed) upon completion of panel alarm report (also see <i>ACCESS TIMEOUT</i>). The panel does not report any alarms during the AVM session except for fire alarms, even if the operator extends the session by pressing any valid key.</li><li>• <b>(2) Callback</b>—Allows the central station operator to place a call to the premises within 5 minutes of the alarm report (panel picks up after one ring). The operator must press * or enter the AVM access code within 20 seconds after ring. The panel does not report any alarms during the AVM session except for fire alarms, even if the operator extends the session by pressing any valid key.</li><li>• <b>(3) Callback Silent</b>—Same as Callback, except premises phones do not ring.</li></ul>	<p>➤ <b>To set Audio Mode:</b></p> <ol style="list-style-type: none"><li>1. With the display showing <i>AUDIO VERIFY OFF/ON</i>, press A or B until the display shows <i>AUDIO MODE nn (current setting)</i>.</li><li>2. Enter the desired mode number (1-3). The display flashes the entered setting. Press # and the display shows the new setting.</li></ol>

<b>Fire Shutdown (09002)</b>	<i>Audio Verification-Partition 1 (Default = off)</i>
This setting determines whether system sirens turn off during a fire alarm audio session.	<p>➤ <b>To turn Fire Shutdown off or on:</b></p> <ol style="list-style-type: none"><li>1. With the display showing <i>AUDIO VERIFY OFF/ON</i>, press A or B until the display shows <i>FIRE SHUTDOWN OFF/ON (current setting)</i>.</li><li>2. Press 1 (off) or 2 (on). The display flashes the entered setting. Press # and the display shows the new setting.</li></ol>

<b>Silent Talkback (09003)</b>	<i>Audio Verification-Partition 1 (Default = off)</i>
This setting determines whether the central station operator can speak to persons on the premises (on) or only listen (off) during a silent or duress alarm audio session.	<p>➤ <b>To turn Silent Talkback off or on:</b></p> <ol style="list-style-type: none"><li>1. With the display showing <i>AUDIO VERIFY OFF/ON</i>, press A or B until the display shows <i>SILENT TALKBACK OFF/ON (current setting)</i>.</li><li>2. Press 1 (off) or 2 (on). The display flashes the entered setting. Press # and the display shows the new setting.</li></ol>

<b>Access Timeout (09004)</b>	<i>Audio Verification-Partition 1 (Default = 90 sec.)</i>
If the Audio Mode is set to “Instant,” then this setting determines how much time (30–300s, in 2-second increments) the central station operator has to enter the AVM access code after the panel is accessed for an audio session.	<p>➤ <b>To change the Access Timeout:</b></p> <ol style="list-style-type: none"> <li>1. With the display showing <i>AUDIO VERIFY OFF/ON</i>, press A or B until the display shows <i>ACCESS TIMEOUT nn SECS (current setting)</i>.</li> <li>2. Enter the desired time. The display flashes the entered setting. Press # and the display shows the new setting.</li> </ol>

<b>Beep Delay (09005)</b>	<i>Audio Verification-Partition 1 (Default = 02 sec.)</i>
This setting determines how long AVM access beeps are delayed (0–300s, in 2-second intervals) at the beginning of a 2-way audio session.	<p>➤ <b>To change the Beep Delay:</b></p> <ol style="list-style-type: none"> <li>1. With the display showing <i>AUDIO VERIFY OFF/ON</i>, press A or B until the display shows <i>BEEP DELAY nn SECS (current setting)</i>.</li> <li>2. Enter the desired time. The display flashes the entered setting. Press # and the display shows the new setting.</li> </ol>

<b>Access Code (09006)</b>	<i>Audio Verification-Partition 1 (Default = **** or none)</i>
This setting determines the code required to access the audio verification module to start an audio session. If no code is programmed, pressing * starts an audio session.	<p>➤ <b>To change the Access Code:</b></p> <ol style="list-style-type: none"> <li>1. With the display showing <i>AUDIO VERIFY OFF/ON</i>, press A or B until the display shows <i>ACCESS CODE nnnn (current code)</i>.</li> <li>2. Enter the desired <b>4-digit access code</b>. The display flashes the entered code. Press # and the display shows the new setting.</li> </ol> <p>➤ <b>To delete an Access Code:</b></p> <ol style="list-style-type: none"> <li>1. With the display showing <i>AUDIO VERIFY OFF/ON</i>, press A or B until the display shows <i>ACCESS CODE nnnn (current code)</i>.</li> <li>2. Press D to delete.</li> </ol>

<b>Vox Mic Gain (09007)</b>	<i>Audio Verification-Partition 1 (Default = 14)</i>
This setting determines the microphone sensitivity for triggering voice-activated switching (VOX). For the Interrogator 200, the default setting (14) is recommended.  Room size, acoustics and furnishings where the Interrogator 200 is located will influence the setting. Setting range is from 01 (low) to 64 (high).	<p>➤ <b>To change the Vox Mic Gain:</b></p> <ol style="list-style-type: none"> <li>1. With the display showing <i>AUDIO VERIFY OFF/ON</i>, press A or B until the display shows <i>VOX MIC GAIN nn (current setting)</i>.</li> <li>2. Enter the desired <b>2-digit setting</b> (01 - 64). The display flashes the entered setting. Press # and the display shows the new setting.</li> </ol>

<b>Vox Gain Range (09008)</b>	<i>Audio Verification-Partition 1 (Default = 64)</i>
This setting determines the gain range for voice-activated switching (VOX).  Setting range is from 01 (low) to 64 (high). For best results, this setting should be higher than the Vox Mic Gain.	<p>➤ <b>To change the Vox Gain Range:</b></p> <ol style="list-style-type: none"> <li>1. With the display showing <i>AUDIO VERIFY OFF/ON</i>, press A or B until the display shows <i>VOX GAIN RANGE nn (current setting)</i>.</li> <li>2. Enter the desired <b>2-digit setting</b> (01 - 64). The display flashes the entered setting. Press # and the display shows the new setting.</li> </ol>

<b>Manual Mic Gain (09009)</b>	<i>Audio Verification-Partition 1 (Default = 64)</i>
Not used.	

<b>Vox RX Gain (09010)</b>	<i>Audio Verification-Partition 1 (Default = 08)</i>
<p>This setting determines the receiver (talkback) gain level for voice-activated switching (VOX). Setting range is 01-10.</p> <p>If the VOX is switching the speaker on when the central station operator is not talking, lower this setting and the VOX Mic Gain setting.</p> <p>If the VOX is <i>not</i> switching the speaker on when the central station operator is talking, raise this setting and lower the VOX Mic Gain setting.</p>	<p>➤ <b>To change the VOX RX Gain:</b></p> <ol style="list-style-type: none"> <li>1. With the display showing <i>AUDIO VERIFY OFF/ON</i>, press A or B until the display shows <i>VOX RX GAIN nn (current setting)</i>.</li> <li>2. Enter the desired <b>2-digit setting</b> (01 - 10). The display flashes the entered setting. Press # and the display shows the new setting.</li> </ol>

### **Accessory Modules Menu**

The *ACCESSORY MODULES* menu gives you access to the following menus:

- *BUS DEVICES*—this menu lets you read bus device unit numbers, assign bus devices to a partition, and configure other features associated with a specific bus device.
- *SNAPCARDS*—this menu lets you set the configuration number for each SnapCard output, assign SnapCard outputs to a partition, and name the SnapCard outputs.

The following describes how to program the settings that appear under *ACCESSORY MODULES—BUS DEVICES*.

<b>Unit-ID (10000 thru 10015)</b>	<i>Acc. Modules-Bus Devices (Default = **** or none)</i>
<p>This menu lets you identify all connected bus devices, view each Unit Number, view the Device ID number, and configure other settings based on a specific device. This menu also lets you delete learned bus devices.</p> <p><b>Note</b> Most settings under <i>ACCESSORY MODULES—BUS DEVICES</i> have no shortcut numbers.</p> <p><i>To help identify bus devices, the 8-digit Device ID number is also located on a label on each Super-Bus 2000 device.</i></p>	<p>➤ <b>To identify bus device Unit and ID:</b></p> <ol style="list-style-type: none"> <li>1. With the display showing <i>BUS DEVICES</i>, press #. The display shows the bus Unit Number and the 8-digit Device ID number. For example: <i>UNIT - ID 0—02110185</i>. Where 0 is the Unit Number and 02110185 is the Device ID number.</li> <li>2. Press A or B to identify all other bus Unit Numbers (0–15) and Device ID numbers.</li> </ol> <p>➤ <b>To delete learned Unit Numbers:</b></p> <ol style="list-style-type: none"> <li>1. With the display showing <i>BUS DEVICES</i>, press #. The display shows the bus device set to Unit Number 0.</li> <li>2. Press A or B until the bus device Unit Number you want to delete is displayed.</li> <li>3. Press D. The display changes the Unit Number to <i>NONE</i>.</li> </ol>

<b>Device ID</b>	<i>Acc. Modules-Bus Devices-Unit ID-Change ID (Default = none)</i>
<p>This menu lets you change the bus device ID number when replacing a defective bus device.</p>	<p>➤ <b>To change a Device ID:</b></p> <ol style="list-style-type: none"> <li>1. With the display showing the desired bus device, press # + #. The display shows <i>DEVICE ID (current ID)</i>.</li> <li>2. Enter the ID of the new bus device. The display flashes the entered selection. Press # and the display shows the new setting.</li> <li>3. Exit programming mode.</li> <li>4. Remove AC and battery power from the panel.</li> <li>5. Replace the defective bus device with a new one.</li> <li>6. Apply AC and battery power to the panel.</li> </ol>

## Partition Assign

Acc. Modules-Bus Devices-Unit ID-Device Partition

This menu lets you assign bus devices to work in the desired partition.

### Note

*SuperBus 2000 8Z Input Modules, SuperBus 2000 4-Relay Output Modules, and SuperBus 2000 RF Receivers are not assigned to partitions.*

### ➤ To assign bus devices to partitions:

1. With the display showing the desired bus device, press #.
2. Press A or B until the display shows *DEVICE PTN* and then press #. The display shows *PARTITION ASSIGN n*.
3. Press 1-6 to select the desired partition. The display flashes the entered selection. Press # and the display shows the new setting.

## Output Programming

Acc. Modules-Unit ID-Outputs

Use these settings to program the output points of any installed SuperBus 2000 Hardwire Output Module. The installer programs a HOM output point into the Concord security panel by entering three kinds of information.

Below describes how to program each of the HOM output point configurations into the security panel. The point configuration number is *tttrr*, where *ttt* is the trigger number and *rr* is the response number.

### Note

*HOM output points cannot be configured for user control. Only the onboard and Snap-Card outputs can be configured for user control.*

- **Partition** -the system partition (1-6).
- **Trigger** - the event that activates the output point. Trigger events can be partition alarms, trouble conditions, open sensors, etc. (see Appendix B: Reference Tables).
- **Response** - how the output responds when trigger event occurs (see Appendix B: Reference Tables).

1. With the display showing the desired bus device, press #.
2. Press A or B until the display shows *OUTPUTS*.
3. Press #. The display shows *OUTPUT 1*.
4. Press A or B to select an output, then press #. The display shows *PARTITION ASSIGN 1*.
5. Press 1-6 to select the desired partition assignment for this relay. The display flashes the entered setting. Press # and the display shows the new setting.
6. Press A or B. The display shows *CONFIGURATION tttrr (current setting)*.
7. Enter the desired 5-digit configuration number for this relay. The display flashes the entered setting. Press # and the display shows the new setting.
8. Press # and repeat steps 4 through 8 until all outputs are programmed

## Status Beeps

Acc. Modules-Bus Devices-Unit ID-Keypad Options  
(Default = on)

This setting determines whether or not the selected touchpad sounds status beeps. Each touchpad can be set individually.

This feature is usually turned off for a touchpad that is located in or near bedrooms, to avoid disturbing sleeping persons.

### Note

*For UL Listed installations, Status Beeps must be set to on.*

### ➤ To turn touchpad Status Beeps on or off:

1. With the display showing the desired touchpad, press # then A or B until the display shows *KEYPAD OPTIONS*.
2. Press # and the display shows *STATUS BEEPS OFF/ON (current setting)*.
3. Press 1 (off) or 2 (on) to select the desired setting. The display flashes the entered selection. Press # and the display shows the new setting.

## Key Beeps

Acc. Modules-Bus Devices-Unit ID-Keypad Options  
(Default = on)

This setting determines whether or not selected touchpads beep when their buttons are pressed.

This feature is usually turned off for a touchpad that is located in or near bedrooms, to avoid disturbing sleeping persons.

### ➤ To turn Key Beeps on or off:

1. With the display showing the desired touchpad, press # then A or B until the display shows *KEYPAD OPTIONS*. Next, press # then A or B until the display shows *KEY BEEPS OFF/ON (current setting)*.
2. Press 1 (off) or 2 (on) to select the desired setting. The display flashes the entered selection. Press # and the display shows the new setting.

<b>Freeze Temp</b>	<i>Acc. Modules-Bus Devices-Unit ID-Energy Options (Default = 42°F)</i>
<p>This setting determines the temperature point that the Energy Saver Module detects a potential freeze (heating failure) condition. The adjustable range is from 40° to 90°F.</p> <p><b>Note</b> This is the same menu found under REPORTING/PARTITIONS 1-6. The setting is used by both the SuperBus 2000 Energy Saver Module and Dialog RF Thermostat. Individual freeze temperature settings for each device are not allowed.</p>	<p>➤ <b>To change the Freeze Temp setting:</b></p> <ol style="list-style-type: none"> <li>1. With the display showing the desired bus device press #, then A or B until the display shows <i>ENERGY OPTIONS</i>. Next, press # then A or B until the display shows <i>FREEZE TEMP nn DEGREES (current setting)</i>.</li> <li>2. Enter the desired freeze temperature (40°–90° F). The display flashes the entered selection. Press # and the display shows the new setting.</li> </ol>

<b>Temperature</b>	<i>Acc. Modules-Bus Devices-Unit ID-Energy Options (Default = none)</i>
<p>This setting lets you adjust the Energy Saver Module (ESM) room temperature setting to match the premises thermostat. The adjustable range is from 40°–90°F.</p> <p><b>Note</b> To ensure accuracy, wait at least 15 minutes before setting the ESM temperature to allow the ESM to warm or cool to actual room temperature.</p>	<p>➤ <b>To change the ESM Temperature setting:</b></p> <ol style="list-style-type: none"> <li>1. With the display showing the desired bus device press #, then A or B until the display shows <i>ENERGY OPTIONS</i>. Next, press # and then A or B until the display shows <i>TEMPERATURE nn DEGREES (current setting)</i>.</li> <li>2. Enter the desired temperature (40°–90° F). The display flashes the entered selection. Press # and the display shows the new setting.</li> </ol>

<b>Cellular System</b>	<i>Acc. Modules-Bus Devices-Unit ID-Cellular Options (Default = B)</i>
<p>This setting determines the cellular transmission system (A or B) used for cellular communication. This information is provided by the cellular provider based on installation ZIP code.</p>	<p>➤ <b>To set the Cellular System:</b></p> <ol style="list-style-type: none"> <li>1. With the display showing the desired bus device press 1, (B) or 2 (A). The display flashes the entered selection.</li> <li>2. Press # and the display shows the new setting.</li> </ol>

The following describes how to program the settings that appear under *SNAPCARDS*.

<p><b>Output Programming</b> (output 1: partition assign-101100, configuration-101101; output 2: partition assign-101110, configuration-101111; output 3: partition assign-101120, configuration-101121; output 4: partition assign-101130, configuration-101131)</p>	<p>Acc. Modules-SnapCards-Output Programming (Defaults: Partition Assign=1, Configuration Output 1= 01400, Output 2 = 00410, Output 3 = 00903, Output 4 = 01003)</p>
<p>This setting lets you assign a partition and a 5-digit configuration number for each SnapCard relay output. This number determines both which system event activates the output and the duration or time the output is activated.</p> <ol style="list-style-type: none"> <li>1. Assign the partition (1-6).</li> <li>2. Assign the configuration number (combination of a trigger number and a response number).</li> </ol> <p>Trigger: the event that activates the output point. Trigger events can be partition alarms, trouble conditions, open sensors, etc. (see Appendix B: Reference Tables).</p> <p>Response: how the output responds when trigger event occurs (see Appendix B: Reference Tables).</p>	<p>➤ <b>To assign configuration numbers to SnapCard Relay outputs (where <i>tttrr</i> is the point configuration number, <i>ttt</i> is the trigger number and <i>rr</i> is the response number):</b></p> <ol style="list-style-type: none"> <li>1. With the display showing <i>SNAPCARDS</i>, press #. Then press A or B until the display shows <i>OUTPUT PROGRAMMING</i>.</li> <li>2. Press # again and the display shows <i>OUTPUT 1</i>.</li> <li>3. Press A or B to select the desired output (1–4), then press #.</li> <li>4. With the display showing <i>PARTITION ASSIGN 1</i>, press 1-6 to select the desired partition. Press # to confirm the partition.</li> <li>5. Press A or B until the display shows <i>CONFIGURATION tttrr</i> (current setting).</li> <li>6. Enter the desired 5-digit configuration number for this relay. Press # to confirm the setting.</li> <li>7. Press # and repeat steps 3 through 6 until all outputs are programmed.</li> </ol>

<p><b>Output Text</b> (output 1: 10120, output 2: 10121, output 3: 10122, output 4: 10123)</p>	<p>Acc. Modules-SnapCards-Output Text (Default = none)</p>
<p>Entering text for an output allows the user to control it directly or by schedule. Use the following guidelines to “name” SnapCard outputs:</p> <ul style="list-style-type: none"> <li>• Use the item numbers that appear in “Appendix B, Table B2” for characters and words listed there.</li> </ul> <p><b>Note</b> If you desire an output for User Output Control you must use the Output Text feature to name the output. If no Output Text is programmed, the user will not have access to the output.</p> <ul style="list-style-type: none"> <li>• If a desired word does not appear in Table B2, create it using the characters (custom text).</li> <li>• When using words from Table B2, spaces between them appear automatically. When using characters from Table B2 to create words, you must reserve an item number for a ‘space’ after the word.</li> <li>• Each character or word uses up one item number. For example, a word from the list counts as one item number. A created word (such as BOY’S) counts as six item numbers—4 letters, 1 apostrophe, and 1 space.</li> <li>• Only 16 item numbers are allowed for each output name, so plan ahead before programming output text. You may need to abbreviate words to avoid running out of item numbers.</li> </ul>	<p>➤ <b>To program Output Text:</b></p> <ol style="list-style-type: none"> <li>1. With the display showing <i>SNAPCARDS</i>, press #, then A or B until the display shows <i>OUTPUT TEXT</i>.</li> <li>2. Press # and the display shows <i>OUTPUT 1</i>.</li> <li>3. Press A or B until the desired output number is displayed.</li> <li>4. Press # and the display shows: <i>OUTPUT N ITEM 0 0 -</i>. Where <i>ITEM 0</i> is the first character/word location and <i>0</i> is the character/word number.</li> <li>5. Enter the number of the desired character or word, or scroll through the numbers by pressing B (forward) or A (backward). If you make a mistake, simply enter the correct number or continue scrolling through choices.</li> <li>6. Press # to accept the displayed choice and the display shows: <i>OUTPUT N ITEM 1 0 -</i>.</li> <li>7. Repeat steps 4 and 5 as needed to complete the output name.</li> <li>8. Press * after entering the last character or word number. The display shows the complete text name. For example: <i>OUTPUT 1 GARAGE DOOR</i>.</li> </ol>

### Onboard Options Menu

The *ONBOARD OPTIONS* menu lets you set up the following built-in options:

- *INPUTS*—This menu lets you turn the Smoke Verification and the Two Wire Smoke features off or on.
- *OUTPUT PROGRAMMING*—This menu lets you set configuration numbers for the two built-in panel outputs and assign the outputs to partitions.
- *OUTPUT TEXT*—This menu lets you assign text to the two built-in outputs so they can be controlled by the user.



The following sections describe the settings that appear under *ONBOARD OPTIONS—INPUTS*.

<b>Smoke Verify (1100)</b>	<i>Onboard Options-Inputs (Default = off)</i>
<p>This setting controls the number of sensor group 26 (fire) zone trips needed to report a fire alarm.</p> <p>When turned off, hardwire and wireless smoke sensor alarms are reported immediately.</p> <p>When turned on,</p> <ul style="list-style-type: none"> <li>• <b>Hardwire Smoke sensors:</b> onboard or SnapCard zones learned into group 26 must be in alarm for at least three seconds or tripped twice within five minutes before activating system sirens and reporting to a central station (or pager).</li> <li>• <b>Wireless Smoke sensors:</b> the first trip of a group 26 RF sensor will cause a local fire alarm. The second trip of any group 26 zone within the siren timeout will cause that fire alarm to be reported to the central station.</li> </ul> <p><b>Note</b>  <i>RF smoke detectors repeat the alarm transmission every 60 seconds as long as they are detecting smoke. This repeated transmission will serve as the second zone trip, causing the alarm to be reported.</i></p>	<p>➤ <b>To turn Smoke Verify off or on:</b></p> <ol style="list-style-type: none"> <li>1. With the display showing <i>ONBOARD OPTIONS</i>, press # twice. The display shows <i>SMOKE VERIFY OFF/ON (current setting)</i>.</li> <li>2. Press 1 (off) or 2 (on). The display flashes the entered number.</li> <li>3. Press # and the display shows the new setting.</li> </ol> <p><b>Note</b>  <i>For California State Fire Marshall Listed installations, this feature must be off.</i></p>

<b>Two Wire Smoke (1101)</b>	<i>Onboard Options-Inputs (Default = off)</i>
<p>This setting determines how onboard hardwire zone 8 is configured. When this setting is on, zone 8 will be configured for two wire smoke detectors. When off, it will be configured for a normal hardwire input.</p>	<p>➤ <b>To turn Two Wire Smoke off or on:</b></p> <ol style="list-style-type: none"> <li>1. With the display showing <i>ONBOARD OPTIONS</i>, press # twice. The display shows <i>SMOKE VERIFY OFF/ON (current setting)</i>.</li> <li>2. Press A or B until the display shows <i>TWO WIRE SMOKE ON/OFF (current setting)</i>.</li> <li>3. Press 1 (off) or 2 (on). The display flashes the entered number. Press # and the display shows the new setting.</li> </ol>

The following sections describe the settings that appear under *ONBOARD OPTIONS—OUTPUT PROGRAMMING*.

<b>Output 1, 2 (Output 1: partition assign-11100, configuration-11101; Output 2: partition assign-11110, configuration-11111)</b>	<i>Onboard Options-Output-Programming (Defaults: Output 1=Ptn 1, 01614; Output 2=Ptn 1, 01710)</i>
<p>This setting lets you assign the partition and the 5-digit configuration number for the two onboard outputs. The configuration number determines</p> <ul style="list-style-type: none"> <li>• which system event activates the selected output, and</li> <li>• the duration or time the output is activated.</li> </ul> <p>The first three digits represent the trigger number of an event (such as triggering an alarm, opening a sensor, or arming the system). The last two digits represent how the output responds (such as momentary switching, maintained (or latched) switching, or switching for a preset time).</p> <p><b>Note</b>  <i>If you want to configure an output for user Output Control you must use the Output Text feature to name the output. If no Output Text is programmed, user Output Control will not function for that output.</i></p> <p>Use the system event trigger and response numbers listed in Appendix B: Reference Tables.</p>	<p>➤ <b>To set up onboard Output 1 &amp; 2 partition and configuration assignments:</b></p> <ol style="list-style-type: none"> <li>1. With the display showing <i>ONBOARD OPTIONS</i>, press # + B. The display shows <i>OUTPUT PROGRAMMING</i>.</li> <li>2. Press # and the display shows <i>OUTPUT 1</i>. Press B to select <i>OUTPUT 2</i>.</li> <li>3. Press # and the display shows <i>PARTITION ASSIGN n (current setting)</i>.</li> <li>4. Press 1-6 to assign the output to the desired partition, then press #. The display shows <i>PARTITION ASSIGN (new setting)</i>.</li> <li>5. Press B and the display shows <i>CONFIGURATION ttrr (current setting)</i>.</li> <li>6. Enter the desired configuration number. The display flashes the entered number. Press # and the display shows the new setting.</li> <li>7. Press # and repeat steps 2 through 6 until all outputs are programmed.</li> </ol>

<b>Output Text (Output 1: 1120, Output 2: 1121)</b>	<b>Onboard Options-Output Text-Output 1, 2 (Default = none)</b>
<p>Entering text for an output allows the user to control it directly or by schedule. Use the following guidelines to “name” onboard outputs:</p> <ul style="list-style-type: none"> <li>Use the item numbers listed in “Appendix B, Table B2” for characters and words.</li> </ul> <p><b>Note</b> If you want to configure an output for user Output Control you must use the Output Text feature to name the output. If no Output Text is programmed, Output Control will not function for that output.</p> <ul style="list-style-type: none"> <li>If a desired word does not appear in Table B2, create it using the characters (custom text).</li> <li>When using words from Table B2, spaces between them appear automatically. When using characters from Table B2 to create words, you must reserve an item number for a ‘space’ after the word.</li> <li>Each character or word uses up one item number. For example, a word from the list counts as one item number. A created word (such as BOY’S) counts as six item numbers—4 letters, 1 apostrophe, and 1 space.</li> <li>Only 16 item numbers are allowed for each output name, so plan ahead before programming output text. You may need to abbreviate words to avoid running out of item numbers.</li> </ul>	<p>➤ <b>To program Output Text:</b></p> <ol style="list-style-type: none"> <li>With the display showing <i>ONBOARD OPTIONS</i>, press # then press B twice and the display shows <i>OUTPUT TEXT</i>.</li> <li>Press # and the display shows <i>OUTPUT 1</i>.</li> <li>Press # and the display shows: <i>OUTPUT 1 ITEM 0 0 -</i>. Where <i>ITEM 0</i> is the first character or word location and <i>0</i> is the character or word number.</li> <li>Enter the number of the desired character or word, or scroll through the numbers by pressing B (forward) or A (backward). If you make a mistake, simply enter the correct number or continue scrolling through choices.</li> <li>Press # to accept the displayed choice and the display shows: <i>OUTPUT 1 ITEM 1 0 -</i>.</li> <li>Repeat steps 4 and 5 as needed to complete the output name.</li> <li>Press * after entering the last character or word number. The display shows the complete text name. For example: <i>OUTPUT 1 GARAGE DOOR</i>.</li> </ol>

### Macro Keys Menu

The *MACRO KEYS* menu lets you set up single-button system commands with the ATP2100 and ATP2600 touchpads.

The following describes how to program the settings that appear under *PARTITION 1-6*.

<b>Macro Keys</b>	<b>Macro Keys (Defaults for all partitions: Macro Key 1—Chime: 71 Macro Key 2—Stay: 2 Macro Key 3—Quick Exit: D; Macro Key 4—Away: 3)</b>
<p>This menu lets you program the Chime, Stay, Exit, and Away macro keys on ATP2100 and ATP2600 touchpads. Macro keys let you perform a system command with one button, eliminating manual entry of the command. For example, the Stay key can be programmed so that it automatically arms the system to level 2 with No Delay just by pressing it once.</p> <ul style="list-style-type: none"> <li>Each partition can accept up to four macros.</li> <li>All touchpads in a partition use the same set of macros.</li> <li>Macro keys can execute a system command up to 14 keypresses in length. Use keys 0-9, #, *, and A-F to program macros.</li> </ul> <p><b>Note</b> It is recommended not to program macros that disarm the system.</p> <ul style="list-style-type: none"> <li>Panic keys, long keypresses (press and hold), and macro keys themselves cannot be used in a macro.</li> <li>When programming a macro to enter user programming, two delays (F key) must be entered after the access code, and before any shortcut number. For example, the macro key sequence for entering the Set Time menu would be 9CODEFF020.</li> <li>When using an ATP2100 or ATP2600 to jump to another partition, pressing the macro buttons on the “jumped” touchpad will execute macro commands based on the macros programmed in the jumped partition.</li> </ul>	<p>➤ <b>To program/change a Macro Key:</b></p> <ol style="list-style-type: none"> <li>With the display showing <i>MACRO KEYS</i>, press #. The display shows <i>PARTITION 1</i>.</li> <li>Press A or B to select the desired partition (1-6), then press #. The display shows <i>MACRO KEY 1 (current setting)</i>.</li> <li>Press A or B to select the desired macro key you want to program (1-4).</li> <li>To change this macro, press the associated macro key. The current setting disappears and is replaced with a flashing cursor.</li> <li>Enter the desired system command. The display flashes the entry.</li> </ol> <p><b>Note</b> If you make a mistake, press the macro key twice to clear the entry and start over.</p> <ol style="list-style-type: none"> <li>Press the macro key again to accept the entered command. The display stops flashing.</li> </ol>

## Exiting Programming Mode

After all installer/dealer programming is completed, use the following procedure to exit programming mode.

### ➤ To exit programming mode:

1. Press \* until the display shows *SYSTEM PROGRAMMING*.
2. Press A or B until the display shows *EXIT PROGRAMMING READY*.
3. Press # and the touchpad displays the *TIME AND DATE*.

## Entering Quick Programming Mode

The Quick Programming Mode allows basic system programming using a SuperBus 2000 Fixed Display Touchpad or any SuperBus 2000 Alphanumeric Touchpad. The following menus are accessible:

- Account Number (all partitions)
- CS Phone 1
- CS Phone 2
- CS Phone 3
- Learn Sensors—limited to selecting sensor number, sensor group, and partition assignment. An alphanumeric touchpad is required for programming sensor text in standard programming mode.

### ➤ To enter Quick Programming Mode:

1. Make sure the system is disarmed in all partitions.
2. Press 8 + installer/dealer CODE + 03. The display shows *ACCOUNT NUMBER*.
3. Cycle through the menus as shown below:

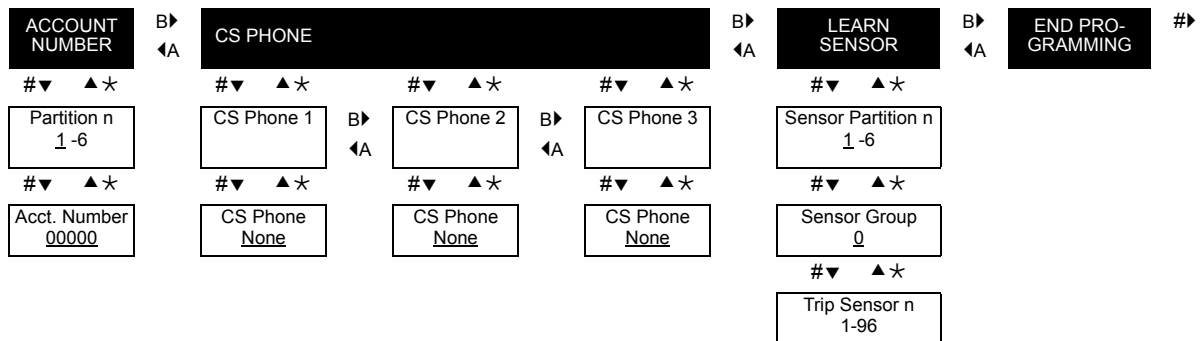

## Entering User Programming Mode

The user programming mode lets you view system version information and program the following system settings:

- Time and Date
- User Codes
- Options
- Set Up Schedules
- Attach Schedules to Events
- Energy Saver
- Attach Lights to Sensors
- System Version

You can enter user programming from an alphanumeric or fixed display touchpad by using the system or partition master code. The default system master code is 1234.

### ➤ To enter user-programming mode:

- ◆ Press 9 + CODE. The display shows *TIME AND DATE*.

## Time and Date Menu

### Note

Setting the time and date is important for accurate tracking of system events stored in the event buffer.

The panel uses a global clock and calendar for time and date. Alphanumeric touchpads display the panel time and date whenever the system is disarmed.

The *TIME AND DATE* menu lets you set this clock and calendar. The following procedures tell you how.

### Time (020)

*Time and Date (Default = 00:00)*

This setting lets you adjust the panel clock to the correct time. The panel uses a 24-hour clock. For example, to set the time to 4:17 P.M., enter 1617.

➤ **To set the Time:**

1. With the display showing *TIME AND DATE*, press # and the display shows *TIME hh:mm (current time)*.
2. Enter the correct time (0000–2359). The display flashes the entered time. Press # and the display shows the new time.

### Date (021)

*Time and Date (Default = 01/01/00)*

This setting lets you adjust the panel calendar to the correct month, day, and year.

➤ **To set the Date:**

1. With the display showing *TIME AND DATE*, press #, then A or B until the display shows *DATE nn/mm/nn (current date)*.
2. Enter the correct month (01–12), day (01–31), and year (00–99). For example, enter 090100 for September 1, 2000. The display flashes the entered date. Press # and the display shows the new date.

## User Codes Menu

The *USER CODES* menu lets you program/change regular user access codes, partition master codes, and the system master code. You can enter up to 230 separate user codes, allowing up to 230 different “users” access to the security system. You can also specify whether or not a specific user is able to perform specific actions like, bypass sensors or test the system.

### User NNN (030nnn0 where nnn=user number 00-229)

*User Codes-Reg. User Codes-User NNN (Default = none)*

User codes perform basic arming and disarming functions. The system allows up to 230 user codes (user numbers 00–229). User numbers that show \*\*\*\* indicate no code is currently programmed for that user number.

➤ **To program Regular User Codes:**

1. With the display showing *USER CODES*, press # and the display shows *REGULAR USER CODES*.
2. Press # and the display shows *USER nnn (first available user number)*.
3. Press A or B to select the desired user number, then press #. The display shows *USER nnn - nnnn*.
4. With the desired user number displayed, enter a 4-digit user code. The display flashes the entered code. Press # and the display shows *USER nnn - nnnn (new code)*.

➤ **To delete Regular User Codes:**

1. With the display showing *USER CODES*, press # and the display shows *REGULAR USER CODES*.
2. Press # and the display shows *USER nnn - nnnn (first available user number)*.
3. Press A or B to select the desired user number/user code you want to delete (if it is not already displayed), then press #. The display shows *USER nnn - nnnn*.
4. Enter the system or partition master code. The display flashes the entered code. Press # and the display shows *USER nnn -- \*\*\*\* (no code)*.

**Direct Bypassing** *User Codes-Reg. User Codes-User NNN (Default = off)*  
*(030nnn1 where nnn=user number 00-229)*

This setting determines whether a specific user code provides access to the “bypass sensors” feature. Set this feature to “on” for all users who need to be able to bypass sensors.

➤ **To turn user code Direct Bypassing off or on:**

1. With the display showing *USER CODES*, press # and the display shows *REGULAR USER CODES*.
2. Press # and the display shows *USER nnn (first available user number)*.
3. Press A or B to select the desired user number, then press #. The display shows *USER nnn - nnnn*.
4. Press A or B until the display shows *DIRECT BYPASSING OFF/ON (current setting)*.
5. Press 1 (off) or 2 (on). The display flashes the entered setting. Press # and the display shows the new setting.

**Remote Access** *User Codes-Reg. User Codes-User NNN (Default = off)*  
*(030nnn2 where nnn=user number 00-229)*

This setting determines whether the user can access the panel from a remote phone (a phone located off the premises).

➤ **To turn user code Remote Access off or on:**

1. With the display showing *USER CODES*, press # and the display shows *REGULAR USER CODES*.
2. Press # and the display shows *USER nn (first available user number)*.
3. Press A or B to select the desired user number, then press #. The display shows *USER nnn - nnnn*.
4. Press B until the display shows *REMOTE ACCESS ON/OFF (current setting)*.
5. Press 1 (off) or 2 (on). The display flashes the entered setting. Press # and the display shows the new setting.

**System Tests** *User Codes-Reg. User Codes-User NNN (Default = off)*  
*(030nnn3 where nnn=user number 00-229)*

This setting determines whether a specific user code provides access to the phone and sensor tests. Set this feature to “on” for all users who need to be able to conduct phone and sensor tests.

➤ **To turn user code System Tests off or on:**

1. With the display showing *USER CODES*, press # and the display shows *REGULAR USER CODES*.
2. Press # and the display shows *USER nnn (first available user number)*.
3. Press A or B to select the desired user number, then press #. The display shows *USER nnn - nnnn*.
4. Press A or B until the display shows *SYSTEM TESTS OFF/ON (current setting)*.
5. Press 1 (off) or 2 (on). The display flashes the entered setting. Press # and the display shows the new setting.

**Latchkey Report** *User Codes-Reg. User Codes-User NNN (Defaults: 00-05 = on, 06-229 = off)*  
*(030nnn4 where nnn=user number 00-229)*

This setting determines whether the user code causes a latchkey report to be sent to a pager when the code is used to change arming levels.

➤ **To assign the Latchkey Report attribute to user codes:**

1. With the display showing *USER CODES*, press # and the display shows *REGULAR USER CODES*.
2. Press # and the display shows *USER nnn (first available user number)*.
3. Press A or B to select the desired user number, then press #. The display shows *USER nnn - nnnn*.
4. Press A or B until the display shows *LATCHKEY OFF/ON (current setting)*.
5. Press 1 (off) or 2 (on). The display flashes the entered setting. Press # and the display shows the new setting.

<b>Partition Assign (030nnn5 where nnn=user number 00-229)</b>	<i>User Codes-Reg. User Codes-User NNN (Default = Ptn 1)</i>
--	--

<p>This setting determines which partitions a user code can access. A code can be assigned to all partitions if desired, making it usable at any touchpad in any partition and able to jump to any selected partition.</p>	<p>➤ <b>To assign Partitions to a user code:</b></p> <ol style="list-style-type: none"> <li>1. With the display showing <i>USER CODES</i>, press # and the display shows <i>REGULAR USER CODES</i>.</li> <li>2. Press # and the display shows <i>USER nnn (first available user number)</i>.</li> <li>3. Press A or B to select the desired user number, then press #. The display shows <i>USER nnn - nnnn</i>.</li> <li>4. Press A or B until the display shows <i>PARTITION ASSIGN (current setting)</i>.</li> <li>5. Enter the desired partitions (1-6). The display flashes the entered numbers. Press # and the numbers stop flashing.</li> </ol>
--	---

<b>Partition Master (0310 - 0315)</b>	<i>User Codes-Partition Master Code (Default = none)</i>
---------------------------------------	--

<p>The Partition Master Code provides access to all system operations and user programming <i>for a single partition</i>.</p> <p><b>Note</b> <i>You must be "in" the partition of the partition master code you wish to change.</i></p>	<p>➤ <b>To change the Partition Master Code:</b></p> <ol style="list-style-type: none"> <li>1. With the display showing <i>USER CODES</i>, press # then A or B until the display shows <i>PARTITION MASTER CODE</i>.</li> <li>2. Press # and the display shows <i>PARTITION nnnn (current code)</i>.</li> <li>3. Enter a new 4-digit code. The display flashes the entered code. Press # and the display shows the new code.</li> </ol>
---	---

<b>System Master (0320)</b>	<i>User Codes-System Master Code (Default = 1234)</i>
-----------------------------	---

<p>The System Master Code provides access to all system operations and user programming.</p> <p><b>Note</b> <i>In the partition where the indicating device (Bell) power is located, only the System Master Code may be enabled to disarm that partition.</i></p>	<p>➤ <b>To change the System Master Code:</b></p> <ol style="list-style-type: none"> <li>1. With the display showing <i>USER CODES</i>, press # then A or B until the display shows <i>SYSTEM MASTER CODE</i>.</li> <li>2. Press # and the display shows <i>SYSTEM MASTER nnnn (current code)</i>.</li> <li>3. Enter a new 4-digit code. The display flashes the entered code. Press # and display shows the new code.</li> </ol>
---	---

### Options Menu

The *OPTIONS* menu lets you set up the system for downloading and silent arming. You can also adjust alphanumeric touchpad display brightness from this menu.

<b>Downloading (041)</b>	<i>Options (Default = on)</i>
--------------------------	-------------------------------

<p>When this setting is on, the panel can communicate with Enterprise Downloader software for programming the system from off-site.</p> <p><b>Note</b> <i>For this feature to work, the panel must be connected to a phone line and be programmed with REMOTE ACCESS on, with a Downloader phone number, and with a Downloader code.</i></p>	<p>➤ <b>To turn Downloading off or on:</b></p> <ol style="list-style-type: none"> <li>1. Press A or B until the display shows <i>OPTIONS</i>.</li> <li>2. Press #, then A or B until the display shows <i>DOWN-LOADING OFF/ON (current setting)</i>.</li> <li>3. Press 1 (off) or 2 (on). The display flashes the entered selection. Press # and the display shows the new setting.</li> </ol>
--	--

<b>Touchpad Brightness (043)</b>	<i>Options (Default = 2)</i>
<p>This setting lets the user lighten or darken the background on touchpad displays. Each touchpad can be set to compensate for lighting conditions in the touchpad location.</p> <p><b>Note</b> This menu appears only if a Phone Interface/Voice Module or a Voice Only Module is connected to the panel.</p>	<p>➤ <b>To adjust Touchpad Brightness:</b></p> <ol style="list-style-type: none"> <li>1. Press A or B until the display shows <i>OPTIONS</i>.</li> <li>2. Press #, then A or B until the display shows <i>TOUCHPAD BRIGHTNESS n (current setting)</i>.</li> <li>3. Enter a setting from 0 (darkest background) to 3 (brightest background). The display flashes the entered selection. Press # and the display shows the new setting.</li> </ol>

<b>Volume (044)</b>	<i>Options (Default = 4)</i>
<p>This setting determines the volume level of status sounds from speakers connected to the Phone Interface/Voice Module or Voice Only Module.</p> <p><b>Note</b> This menu appears only if a Phone Interface/Voice Module or a Voice Only Module is connected to the panel.</p>	<p>➤ <b>To adjust status sound Volume:</b></p> <ol style="list-style-type: none"> <li>1. Press A or B until the display shows <i>OPTIONS</i>, then press #.</li> <li>2. Next, press A or B until the display shows <i>VOLUME n (current setting)</i>.</li> <li>3. Enter a setting from 0 (off) to 7 (loudest). The display flashes the entered selection. Press # and the display shows the new setting.</li> </ol>

<b>Voice Chime (045)</b>	<i>Options (Default = on)</i>
<p>This setting determines whether speakers connected to the Phone Interface/Voice Module or Voice Only Module announce perimeter sensor/zone numbers that are tripped when the Chime feature is on. For example, “Sensor one open.”</p> <p><b>Note</b> This menu appears only if a Phone Interface/Voice Module or a Voice Only Module is connected to the panel.</p>	<p>➤ <b>To turn Voice Chime off or on:</b></p> <ol style="list-style-type: none"> <li>1. Press A or B until the display shows <i>OPTIONS</i>.</li> <li>2. Press # then A or B until the display shows <i>VOICE CHIME OFF/ON (current setting)</i>.</li> <li>3. Press 1 (off) or 2 (on). The display flashes the entered selection. Press # and the display shows the new setting.</li> </ol>

<b>Chime On Close (046)</b>	<i>Options (Default = off)</i>
<p>When this setting is on, the panel sounds a single chime when a perimeter door or window is closed.</p>	<p>➤ <b>To turn Chime On Close off or on:</b></p> <ol style="list-style-type: none"> <li>1. Press A or B until the display shows <i>OPTIONS</i>.</li> <li>2. Press # then A or B until the display shows <i>CHIME ON CLOSE OFF/ON (current setting)</i>.</li> <li>3. Press 1 (off) or 2 (on). The display flashes the entered selection. Press # and the display shows the new setting.</li> </ol>

### **Set Up Schedules Menu**

The *SET UP SCHEDULES* menu lets you set up time frames for light control, output control, automatic arming, latchkey times, and exception opening/closing reports. The system (all partitions) allows you to set up to 16 schedules (00–15) which are shared by all partitions.

Setting up schedules consists of setting a start and stop time for each schedule, then selecting which days of the week the schedule will be active. You can also set up a *rollover* schedule, which starts on one day and ends on another day. This saves programming time and leaves more schedules available (in case they are needed later).

**Rollover Schedule Example:** To set up a schedule to rollover from Tuesday evening to Wednesday morning, set a schedule start time for 2200 (10:00 P.M.) and a stop time for 0500 (5:00 A.M.). Set the schedule to turn on Tuesday. Because the stop time is set for morning, the system automatically carries the schedule over to the next day.

If you use the same start and stop times described above and set the schedule to turn on Monday through Friday, then one schedule will cover the entire week.

**Set Up Schedules** (05XXY, where XX=schedule 00-15 and Y=start [0]/stop[1] Monday thru Sunday [2-8])

(Default = 00:00)

This menu lets you set up start/stop times for each day of the week.

Schedules used by one partition cannot be viewed or changed from a different partition.

**Note**  
If you are programming schedules for your customer, be sure to record the settings in the User's Manual.

➤ **To set up a Time Schedule:**

1. Press A or B until the display shows *SET UP SCHEDULES*.
2. Press # and the display shows *SCHEDULE 00*. If you want a different schedule number, press A or B until the desired schedule number appears.
3. Press # and the display shows *START TIME hh:mm (current setting)*.
4. Enter the desired starting time (00:00–23:59). The display flashes the entered time. Press # and the display shows *START TIME hh:mm (new setting)*.
5. Press B and the display shows *STOP TIME hh:mm (current setting)*.
6. Enter the desired stop time (00:00–23:59). The display flashes the entered time. Press # and the display shows *STOP TIME hh:mm (new setting)*.
7. Press B and the display shows *MONDAY OFF/ON (current setting)*. To select a different day, continue pressing B until the desired day appears.
8. Press 1 (off) or 2 (on). The display flashes the entered selection. Press # and the display shows the new setting for the selected day.
9. Repeat steps 7 and 8 until all desired settings for each day are set.

### Attach Schedules to Events Menu

The *ATTACH SCHEDULES TO EVENTS* menu lets you link the following system events to time schedules:

- **Latchkey Opening**—sends a report if system is disarmed within the attached time schedule.
- **Latchkey Closing**—sends a report if system is armed within the attached time schedule.
- **Exception Opening**—sends a report if system is not disarmed within the attached time schedule.
- **Exception Closing**—sends a report if system is not armed within the attached time schedule.
- **Lights (1–9)** activate X10 controlled lights by the attached time schedule.
- **Outputs (1–6)** allow users to attach onboard (1–2) and SnapCard outputs to a schedule.
- **Arming**—Allows the user to arm the panel at the schedule start time.

**Latchkey Reports** (Opening: 060nn, Closing: 061nn, where nn=Schedule number [0 to 15])

Attach Schedules to Events (Default = off)

This setting lets you attach the Latchkey Opening report feature and the Latchkey Closing report feature to time schedules.

➤ **To Attach a Schedule to Latchkey Opening or Latchkey Closing:**

1. Press A or B until the display shows *ATTACH SCHEDULES TO EVENTS*.
2. Press # then A or B until the display shows *LATCHKEY OPENING OR LATCHKEY CLOSING*.
3. Press # and the display shows *SCHEDULE 00 OFF/ON (current setting)*. If you want a different schedule, press A or B until the desired schedule appears.
4. Press 1 (off) or 2 (on). The display flashes the entered selection. Press # and the display shows the new setting for the selected schedule.



**Exception Reports** (Opening: 062nn, Closing: 063nn, where nn=Schedule number [0 to 15])

Attach Schedules to Events (Default = off)

This setting lets you attach the Exception Opening report feature and the Exception Closing report feature to time schedules.

➤ **To Attach a Schedule to Exception Opening or Exception Closing:**

1. Press A or B until the display shows *ATTACH SCHEDULES TO EVENTS*.
2. Press # then A or B until the display shows *EXCEPTION OPENING OR EXCEPTION CLOSING*.
3. Press # and the display shows *SCHEDULE 00 OFF/ON (current setting)*. If you want a different schedule, press A or B until the desired schedule appears.
4. Press 1 (off) or 2 (on). The display flashes the entered selection. Press # and the display shows the new setting for the selected schedule.

**Lights** (064xnn where nn=Schedule number [0 to 15] and x=light number [1 to 9] minus 1)

Attach Schedules to Events (Default = off)

This setting lets you attach light controls to a time schedule.

➤ **To Attach Schedules to Lights:**

1. Press A or B until the display shows *ATTACH SCHEDULES TO EVENTS*.
2. Press # then A or B until the display shows *LIGHTS*. Press # to enter the *LIGHTS* menu.
3. Press A or B until the desired light appears.
4. Press # and the display shows *SCHEDULE 00 OFF/ON (current setting)*. If you want a different schedule, press A or B until the desired schedule appears.
5. Press 1 (off) or 2 (on). The display flashes the entered selection. Press # and the display shows the new setting for the selected schedule.
6. Repeat steps 3, 4, and 5 until all desired lights are attached to schedules.

**Outputs** (065xnn where nn=Schedule number [0 to 15] and x=output number [1 to 6] minus 1)

Attach Schedules to Events (Default = off)

This setting lets you attach outputs to a time schedule. Onboard outputs are 1–2, Snap-Card outputs are 3–6.

**Note**

Only onboard and SnapCard outputs can be scheduled. These outputs can only be scheduled if:  
a). output text has been entered in installer programming, and  
b). the output is assigned to the same partition as the touchpad used for schedule attachment.

➤ **To Attach Schedules to Outputs:**

1. Press A or B until the display shows *ATTACH SCHEDULES TO EVENTS*.
2. Press # then A or B until the display shows *OUTPUTS*. Press # to enter the *OUTPUTS* menu.
3. Press A or B until the desired output appears.
4. Press # and the display shows *SCHEDULE 00 OFF/ON (current setting)*. If you want a different schedule, press A or B until the desired schedule appears.
5. Press 1 (off) or 2 (on). The display flashes the entered selection. Press # and the display shows the new setting for the selected schedule.
6. Repeat steps 3, 4, and 5 until all desired outputs are attached to schedules.

**Arming** (0660nn where nn=Schedule number [0 to 15])

Attach Schedules to Events (Default = off)

This setting lets you arm according to a time schedule.

**Note**

This setting will allow you to arm to AWAY only. There is no disarm schedule.

➤ **To Attach Schedules to Arming:**

1. Press A or B until the display shows *ATTACH SCHEDULES TO EVENTS*.
2. Press # then A or B until the display shows *ARMING*.
3. To select arm to AWAY press #.
4. Press # and the display shows *SCHEDULE 00 OFF/ON (current setting)*. If you want a different schedule, press A or B until the desired schedule appears.
5. Press 1 (off) or 2 (on). The display flashes the entered selection. Press # and the display shows the new setting for the selected schedule.
6. Repeat steps 4 and 5 until all desired schedules are attached.

### Energy Saver Menu

The *ENERGY SAVER* menu lets you set the Energy Saver Module or Dialog RF Thermostat low- and high-setpoints. These setpoints override the premises thermostat allowing the Energy Saver Module or Dialog RF Thermostat to activate the furnace/air conditioner.

<b>Low Setpoint (070)</b>	<b>Energy Saver (Default = 50°F)</b>
<p>This setting determines the temperature at which the energy saver module relay closes to activate the furnace.</p> <p><b>Note</b> The low setpoint cannot be set equal to or higher than the high setpoint.</p>	<p>➤ <b>To set the Low Setpoint:</b></p> <ol style="list-style-type: none"><li>1. With the display showing <i>ENERGY SAVER</i>, press #, then A or B until the display shows <i>LOW SETPOINT nn DEGREES (current setting)</i>.</li><li>2. Enter the desired temperature (45–89°). The display flashes the entered setting. Press # and the display shows the new setting.</li></ol>

<b>High Setpoint (071)</b>	<b>Energy Saver (Default = 90°F)</b>
<p>This setting determines the temperature at which the energy saver module relay closes to activate the air-conditioner.</p> <p><b>Note</b> The high setpoint cannot be set equal to or lower than the low setpoint.</p>	<p>➤ <b>To set the High Setpoint:</b></p> <ol style="list-style-type: none"><li>1. With the display showing <i>ENERGY SAVER</i>, press #, then A or B until the display shows <i>HIGH SETPOINT m DEGREES (current setting)</i>.</li><li>2. Enter the desired temperature (46–90°). The display flashes the entered setting. Press # and the display shows the new setting.</li></ol>

### Attach Lights to Sensors Menu

The *ATTACH LIGHTS TO SENSORS* menu lets you assign a light number to a sensor. Each time the sensor is activated, the attached light will turn on for 5 minutes. When the 5 minute timer expires the light will turn off. If the same light is scheduled, it will only turn on during the schedule time.

<b>Light X to Sensor Y (08n where n=light number [1-9] minus 1)</b>	<b>Attach Lights to Sensors (Default = 0)</b>
<p>This menu attaches light x to sensor y. Each time a selected sensor is tripped, the selected light will turn on and a 5 minute timer will start.</p> <p><b>Note</b> The sensor must be learned into the current partition before it can be attached.</p>	<p>➤ <b>To attach a light to a sensor:</b></p> <ol style="list-style-type: none"><li>1. With the display showing <i>LIGHT 1 TO SENSOR y</i> (current setting), press A or B to select the desired light number.</li><li>2. Enter the desired sensor number (01–96). The display flashes the entered setting. Press # and the display shows the new setting.</li><li>3. Repeat steps 1 through 2 until all desired lights are attached to sensors.</li></ol> <p>➤ <b>To detach a light from a sensor:</b></p> <ol style="list-style-type: none"><li>1. With the display showing <i>LIGHT 1 TO SENSOR y</i> (current setting), press A or B to select the desired light number.</li><li>2. Enter 0 as the sensor number and press #.</li></ol>

## System Version Menu

The *SYSTEM VERSION* menu lets you view and identify panel hardware and software. This information is primarily used for troubleshooting purposes.

**System Version (Factory Code: 010, System Number: 011, System Level: 012, Software Version: 013)**

(Default = N/A)

This menu lets you view and identify panel hardware and software version.

➤ **To view and identify the System Version:**

1. Press A or B until the display shows *SYSTEM VERSION*.
2. Press # and the display shows *FACTORY CODE nnn\*nnnn*.
3. Press B and the display shows *SYSTEM NUMBER \*nnnnnnnn*.
4. Press B again and the display shows *SYSTEM LEVEL nnnn*.
5. Press B again and the display shows *SW VERSION nnnnx* (panel firmware version).

**Note**

*Downloader programming has not been investigated by UL.*

**Note**

*A Downloader Phone Number must be programmed and the user-programmable option "Downloading" must be on for remote downloader programming to work.*

## Downloader Programming

The panel can be programmed remotely using Enterprise. Use the information you recorded in Appendix A to inform the downloading operator of the programming requirements for this system.

## Enterprise Downloader Programming

➤ **To initiate a Enterprise download session:**

1. Contact your download station and ask the operator to prepare to download to the panel.
2. Make sure the system is disarmed.
3. Press 8 + system master code + 7 + 0 (any), 1 (down), or 2 (up). The display shows *SYSTEM DOWNLOAD IN PROGRESS* during the downloading process.

If the alphanumeric touchpad does not display *SYSTEM DOWNLOAD IN PROGRESS*, call the downloader operator to verify the downloader phone number. Also, make sure ToolBox is set up properly. Refer to the "Troubleshooting" section if the problem persists.

## Testing the System

**Note**

*Before testing, it is recommended that you have covers on all modules (mounted outside the cabinet) and the panel cabinet door closed. The testing environment should match the system working environment.*

This section describes the following:

- Basic System Commands
- Testing Zones/Sensors
- Testing Phone Communication
- Testing Central Station Communication
- Testing Outputs and Sirens
- Testing Light Control
- Testing the Energy Saver Module
- Changing Fixed Display Touchpads
- Testing the Audio Verification Module
- Testing Cellular Backup Communication

You should test the system after installing or servicing and after adding or removing devices from the system.

Refer to the "Troubleshooting" section if correct test results are not achieved.

## Basic System Commands

Table 8 describes basic touchpad operating commands. For complete details on system operation, including user programming, refer to the system *User's Manual*.

**Table 8: Basic Touchpad Commands**

Command	System Response
* (STATUS)	Indicates current system status
* + *	Indicates AC power, battery, and current system status
1 + CODE	Disarms system to OFF
2 + CODE	Arms system to STAY
3 + CODE	Arms system to AWAY
2 (quick arm on)	Arms system to STAY
3 (quick arm on)	Arms system to AWAY
2 or 3 + CODE + 4 or 2 or 3 + 4	Arm system—No Delay (no exit or entry delay)
5 + 2 or 3 + CODE or 5 + 2 or 3	Arms system silently (no arming status beeps)
7 + 1	Turns chime feature on and off
7 + 2	Turns Energy Saver on and off
7 + 4	Partition jump without entering code (only if Partition Security option is off)
7 + 6	Identifies alarms in memory
7 + 7 + n (n = output number [1–6]) 1–2 = onboard outputs 3–6 = module outputs	Turns the output on or off. (This command is only functional after output text is entered into panel memory.)
8 + CODE + 2	Initiates a phone test
8 + CODE + 3	Initiates a sensor test
8 + installer CODE + 3	Initiates a dealer sensor test
8 + CODE + 6	Partition jump
8 + CODE + 8	View Event History
0 + 0	Turns all controlled lights on and off
0 + n (n = light number 1-9)	Turns individual controlled light on and off

## Testing Zones/Sensors

Test sensors/zones after all programming is completed, whenever there is a change in environment, equipment, or programming, and whenever a zone- or sensor-related problem occurs.

If the system does not respond as described in the following procedure, see the “Troubleshooting” section.

1. Place all sensors and zones in their non-alarm state.
2. At an alphanumeric touchpad, enter the sensor test mode by pressing 8 + installer code + 3. The touchpad sounds one beep and displays *SENSOR TEST*. The panel starts a 15 minute timer.
3. Trip each zone/sensor one at a time. Touchpads (and interior sirens) should sound one short, high-pitched beep and the display should show the sensor name (or number) and *OK*.
4. Press the STATUS button when you think all zones/sensors are tested. The touchpad displays any untested sensors/zones and touchpad panics. If all sensors/zones and touchpad panics have been tested, the display shows *SENSOR TEST OK*.
5. Test any untested zones/sensors and touchpad panics.
6. The system stays in sensor test mode for 15 minutes. When less than 5 minutes remain, touchpads and interior sirens beep and the panel announces the remaining time over the speakers once every minute. After 15 minutes the panel disarms to *OFF*, automatically. If you need more time to complete the sensor test, press 8 + installer CODE + 3 while the system is still in sensor test mode. This restarts the 15 minutes of test time.

### Note

While the sensor test is a valuable installation and service tool, it only tests sensor operation for the current conditions. You should perform a sensor test after any change in environment, equipment, or programming.

### Note

If you hear a long, low-pitched beep, proceed to the following section “If a Wireless Sensor Does Not Test.”

7. When all sensors/zones and touchpad panics have been tested, press 1 + installer CODE to exit sensor test mode.

### **If a Wireless Sensor Does Not Test**

If touchpads display *SENSOR FAILURE* and sirens sound a long, low-pitched beep when a zone or sensor is tripped, this indicates that the wireless sensor signal strength is below acceptable limits. Distance from the receiver, the installation environment, or both, are most likely affecting the sensor signal strength.

When possible, locate wireless sensors within 100 feet of the panel. While a transmitter may have a range of 1,000 feet or more out in the open, the environment at the installation site can have a significant effect on transmitter range. Refer to the “Troubleshooting” section to resolve the problem.

For wireless sensors that don’t respond, use an RF Sniffer (60-401) test tool to verify that the sensor is transmitting. Constant beeps from the RF Sniffer indicate a runaway (faulty) sensor. Remove the sensor battery(s) and replace the sensor.

### **Testing Phone Communication**

Perform a phone test to check the phone communication between the panel and the central monitoring station.

➤ **To perform a phone test:**

1. Contact the central monitoring station to inform them that you are testing the system.
2. Press 8 + system master CODE + 2. The display reads *PHONE TEST* and the touchpad sounds one beep. When the panel completes the test, the system returns to the previous arming level automatically.

If the display continues to show *PHONE TEST* for 1½ minutes or more, enter 1 + system master CODE and refer to the “Troubleshooting” section.

### **Testing Central Station/Pager Communication**

After performing sensor and phone tests, check that the system is reporting alarms successfully to the central station or pager.



**Be sure to contact the central monitoring station *before* activating outputs that trigger from an alarm condition.**

**Caution**

➤ **To test communication with the central station/pager:**

1. Call the central station and tell the operator that you will be testing the system.
2. Arm the system.
3. Test each of the touchpad and wireless panic buttons and trip at least one sensor of each type (fire, intrusion, etc.) to verify correct operation.
4. Check pager displays to verify reports are received. Pagers display an event code, digit sensor number, and the last four digits of the account number. For example, a pager display of 999 002 7468 indicates the following:  
999 = alarm condition,  
002 = sensor/zone in alarm or user number,  
7468 = last four digits of account number.
5. When you finish testing the system, call the central monitoring station to verify that the alarms were received.

Table 9 describes pager system event codes.

**Note**

*The way information is displayed varies with pager services and may not match the example above. Account numbers with alpha-characters also vary when displayed, depending on pager service. Account numbers are not displayed if STREAMLINING is turned on.*

**Table 9: Pager System Event Codes**

Code	System Event
009	Zone Restoral
111	System Disarmed
115	Sensor Test Exit
118	Trouble condition cleared
119	Alarm Canceled
222	System Armed to STAY
333	System Armed to AWAY
555	Phone/Sensor Test
888	System Trouble Condition
999	System in Alarm

Table 10 describes pager sensor/zone number and user number report codes.

**Table 10: Pager Sensor/Zone Code and Numbers**

Code	Sensor/Zone or User Number
000	System event not caused by a zone or user
001–096	Sensor/Zone Numbers 1–96
600–829	Regular User Codes 0–229 used
830–837	Partition Master Code used
838–845	Partition Duress Code used
846	System Master Code used
847	Installer Code used
848	Dealer Code used
850	Quick Arm used
851	Keyswitch Sensor used
852	System Armed Itself (during service or power-up)

### **Testing Outputs and Sirens**

All outputs (onboard and SnapCard) should be tested to verify configuration programming.



**Caution**

Be sure to contact the central monitoring station *before* activating outputs that trigger from an alarm condition.

➤ **To test outputs:**

1. Contact the central monitoring station to inform them you are testing the system.
2. Verify that all wiring at the panel and output devices is correct.
3. Activate the appropriate device to trigger each output as programmed.
4. Verify that each output responds according to the programmed configuration number. For outputs that trigger sirens, verify that the correct alarm sounds are produced from these sirens. Table 11 describes the system alarm sounds you should hear for each alarm event.
5. Contact the central monitoring station when you are finished testing.

**Table 11: System Alarm Sounds**

Alarm Type	Alarm Sound
Fire	Repeating series of three beeps
Police/Intrusion	Continuous tone
Auxiliary	Rapid beeps

## Testing Light Control

Test all lights plugged into X10 Lamp Modules to verify house code and light number settings.

### ➤ To test light control:

1. Press 0 + 0 repeatedly to turn all lights on and off together.
2. Press 0 + 1 repeatedly to turn light 1 on and off.
3. Repeat step 2 for remaining lights (0 + 2 for light 2, 0 + 3 for light 3, etc.).
4. Arm the system to Away. All lights plugged into modules set to Unit 1 (or set as entry lights) should turn on and stay on for 5 minutes. All lights plugged into modules set to Unit 2 should blink three times to indicate the arming level. Remaining lights should not be affected.
5. Disarm the system. If Unit 1 (or entry) lights were on for an entry or alarm, they will turn off in 5 minutes. Unit 2 lights should blink once to indicate the system is off. Remaining lights should not be affected.
6. All lights should turn on and remain on during fire and auxiliary/medical alarms. All lights should flash during a police or intrusion alarm.

## Testing the Energy Saver Module (ESM)

Test the Energy Saver Module to verify it overrides the thermostat.

### ➤ To test the Energy Saver Module:

1. Press \* (status) + \* (status) to display the system status, *ENERGY SAVER OFF*, and the present *TEMPERATURE nm°*. The temperature displayed (and/or announced) should match the house thermostat. If the temperatures do not match, refer to the *ACCESSORY MODULES—BUS DEVICES* menu in the “Programming” section.
2. Press 7 + 2 to turn on the ESM. The display shows *ENERGY SAVER ON* and the ESM relay will click once.
3. Press 7 + 2 again to turn the ESM off. The display shows *ENERGY SAVER OFF*.

## Changing Fixed Display LCD Touchpad Chime and Trouble Beep Tones

The frequency (pitch) of chime and trouble beep tones from a fixed display touchpad can be adjusted to a more desirable or distinct tone, or to compensate for hearing impaired persons.

### ➤ To change status tone pitch:

1. Press and hold the \* and 0 buttons together until you hear a steady tone, then release the buttons.
2. Press and hold 1 to lower the pitch or press and hold 2 to raise the pitch.
3. Release the button when the desired pitch is heard.

After about 15 seconds of no touchpad activity, the steady tone stops sounding.

## Adjusting Touchpad Display Contrast

Touchpad displays can be adjusted for easier viewing to help compensate for lighting conditions in the touchpad location. The contrast adjustment lightens or darkens the text.

### ➤ To adjust display contrast:

1. Enter configuration mode by pressing the D and 6 buttons together for at least two seconds. The display shows *DA mnn*.
2. Press and release the 1 and 2 buttons together repeatedly, until the desired contrast level is displayed.
3. Press \* and the display briefly shows *DONE*, then shows the time and date.

## Testing Audio Verification Module (AVM) Communication

Test the Audio Verification Module from off-site and the central station to verify that it works properly.

### ➤ To test the module from off-site:

You will need a helper and touch-tone phone at an off-site location to perform this test. When testing the AVM from off-site the following guidelines must be followed.

- The Remote Access feature must be set to on (default).

### Note

The system must have high- and low-temperature limits set to test the Energy Saver Module.

### Note

There is a 5-minute delay after the Energy Saver Module returns control to the furnace/AC before it will override the furnace/AC again.

### Note

Chime and trouble beep tones sound using the default frequency during, or within 15 seconds of, any button activity at that specific touchpad.

### Note

Vacuum fluorescent displays do not have a contrast adjustment.

- The Audio Verify feature must be set to on.
  - The system must be in a non-alarm state.
  - Optional Ring/Hang/Ring feature must be on (default) to work with steps 1 and 2 below. Otherwise wait for 12 rings and the panel will pick up automatically.
1. The off-site helper calls the panel, lets the phone ring twice, and hangs up.
  2. The helper must call the panel again in 10 to 40 seconds. The panel answers *System hello*.
  3. The helper dials the following on the phone, # 1234 # 8 (AVM access CODE) 5.
  4. The helper should now be able to hear you through the AVM.
  5. Walk through the vicinity of the AVM while speaking at a normal conversation level.
  6. Tell the helper to dial a 1 and speak to you. To return to listen mode, the helper dials a 3.
  7. When testing is complete, have the helper dial 99 and hang up.
- **To test the module with the central station:**
1. Inform the central station that you will be sending an alarm and testing an AVM.
  2. Give them the programming selections you made for the panel (see “Audio Verification Menu” for programming information).
  3. Use a touchpad panic button to initiate an auxiliary alarm.
  4. The central station operator waits for the alarm to be reported and initiates an audio session.
  5. Walk through the vicinity of the AVM while speaking at a normal conversation level.
  6. Have the operator speak to you.
  7. When testing is complete, the operator will end the session.

### Testing Cellular Backup Communication

Perform this test to check the cellular communication between the panel and the central monitoring station.

- **To test Cellular Communication:**
1. Contact the central monitoring station to inform them that you are testing the system.
  2. Install and activate the SuperBus 2000 Cellular Backup Module.
  3. Verify or change the following CS PHONE 1 panel option settings shown in Table 12.

**Table 12: Current Phone Settings**

CS PHONE 1 Option	Test Setting	Previous Setting
PHONE NUMBER	Central station phone number	
HIGH LEVEL RPTS	ON	
BACKUP	OFF*	
CELLULAR BACKUP	ON	
* Can be set to ON if no CS PHONE 2 PHONE NUMBER is programmed.		

**Note**  
If the current settings do not match the test settings, record the current settings (Table 12), so that they can be restored when this test is complete.

4. Disconnect the phone line by unplugging the Db-8 cord from the RL-31X Jack.
5. Initiate a phone test (8 + System Master Code + 2).
6. The phone test attempt should fail via the phone line within 5 minutes. The panel will emit a long low tone (and speak “phone failure 1” if so equipped).
7. Wait for the phone test to succeed via the cell backup. The panel should emit a short high tone (and speak “phone test ok” if so equipped).
8. Verify the CS report.
9. If success does not occur, verify that the signal strength (RSSI) shown on the Cellular Backup Module is acceptable and repeat steps 5-8.
10. Restore previous CS PHONE 1 settings if needed.



## Troubleshooting

This section describes what to do if you experience problems with system operation. If after performing the troubleshooting procedures the panel still malfunctions, please call Technical Support at 1-800-777-2624.

Feature	Problem	Action/Solution
<b>Panel Power</b>		
	Panel does not power up. Touchpads don't display or respond.	<ol style="list-style-type: none"> <li>1. Verify that the panel transformer is plugged into an unswitched outlet.</li> <li>2. Check the AC circuit breaker to be sure the circuit is live.</li> <li>3. Check that the backup battery is installed correctly and the AC power transformer is plugged in.</li> <li>4. Check for proper panel and transformer wiring.</li> <li>5. Measure the incoming AC voltage at panel terminals 1 and 2. It should read about 16.5 VAC.</li> </ol>
	No incoming AC voltage at panel terminals 1 and 2.	<ol style="list-style-type: none"> <li>1. Unplug the AC power transformer and disconnect the wires from the transformer and the panel.</li> <li>2. Check transformer to panel wire for short or open circuits.</li> <li>3. Plug in the transformer and check for 16.5 VAC at the transformer unconnected terminals. If zero (0) volts, replace the transformer.</li> </ol>
	Touchpad display indicates <i>System Low Battery</i> or voice sounds " <i>System low battery.</i> "	<ol style="list-style-type: none"> <li>1. Check that the backup battery is installed correctly and the AC power transformer is plugged in.</li> <li>2. Measure the incoming AC voltage at panel terminals 1 and 2. It should read about 16.5 VAC.</li> <li>3. Check for 11.75 to 13.8 VDC battery voltage between the backup battery spade lugs. If the battery voltage is <b>not</b> within this range, replace the battery.</li> </ol> <p><b>Note</b>  <i>When the panel is running a backup battery test, the reading at the connected battery can range from 11.2 to 13.5 VDC. The panel automatically runs a backup battery test under the following conditions: (1) on initial power-up, (2) during user sensor test, (3) once every minute when backup battery has failed, (4) once every 24 hours at the programmed STIME (UL 98 Options off) or once every 4 hours (UL 98 Options on).</i></p> <p><i>With the AC power transformer plugged in, the panel automatically charges the battery. While the battery is charging for the first time it is normal for the system to indicate System Low Battery. This can take a number of hours depending on the initial battery charge. Once the battery reaches 12.5 VDC (full charge as measured while in battery test), the condition clears. If the trouble condition persists after 24 hours, replace the backup battery.</i></p>
	The touchpads flash AC or display AC Power Failure/AC Failure After pressing <b>STATUS</b> . (Panel continues to operate from backup battery).	<ol style="list-style-type: none"> <li>1. Check the AC circuit breaker to be sure the circuit is live.</li> <li>2. Check for proper panel and transformer wiring.</li> <li>3. Check that the transformer is plugged into a nonswitched outlet and secured with the provided screw.</li> <li>4. Check that the transformer is supplying AC to the panel. (Transformer internal fuse may be blown.)</li> </ol> <div style="display: flex; align-items: center; margin-top: 10px;">  <div style="margin-left: 10px;"> <p><b>Be careful when securing the transformer to an outlet with a metal cover. Hold the cover tightly in place. You could receive a serious shock if the metal outlet cover drops down onto the prongs of the plug while you are securing the transformer and cover to the outlet box.</b></p> <p><b>Warning</b></p> </div> </div>
<b>Access Codes</b>		
	Customer cannot remember access code(s).	<ol style="list-style-type: none"> <li>1. Check your records to see if you have the customer's access code(s) on file.</li> <li>2. Verify the access code(s) using the Downloader.</li> <li>3. Clear memory and reprogram the panel locally.</li> <li>4. Clearing the memory will erase onboard hardware zone factory programming.</li> </ol>
	Installer cannot remember install code.	

Feature	Problem	Action/Solution
		<ol style="list-style-type: none"> <li>1. Check your records to see if you have the install code on file.</li> <li>2. Verify the install code using the Downloader.</li> <li>3. Use the Dealer Code to enter program mode and view the installer code.</li> </ol>
	Installer cannot remember dealer code.	Check your records to see if you have the dealer code on file.
<b>Arming and Disarming</b>		
	System protests and won't arm.	<ol style="list-style-type: none"> <li>1. If arming to level 2, make sure all monitored perimeter doors and windows are closed.</li> <li>2. If arming to level 3, make sure all perimeter and interior sensors are closed.</li> <li>3. Press <b>STATUS</b> for an indication of the problem.</li> </ol>
	System won't disarm.	<ol style="list-style-type: none"> <li>1. Disarming using incorrect code. Enter correct code.</li> <li>2. Access code is not programmed or set up in user programming to disarm system.</li> <li>3. Wireless touchpad is not learned into system or hardwire touchpad is not communicating to panel. Check installer programming for learned wireless touchpads.</li> <li>4. The installer code is being used to disarm the system. The system is designed <i>not to disarm</i> using the installer code. Use a regular or system master code to disarm the system.</li> </ol>
<b>Bypassing</b>		
	Touchpad indicates <i>Invalid</i> and/or " <i>Invalid</i> " is heard when you attempt to bypass a sensor.	<ol style="list-style-type: none"> <li>1. Attempting to bypass a 24-hour sensor that cannot be bypassed (group 26 fire sensors).</li> <li>2. Sensor is not active in the current arming level.</li> </ol>
	System cancels sensor bypass when you try to arm to level 2 or 3.	Sensor is being bypassed before arming to 2—STAY or 3—AWAY. Arm to the desired level before bypassing a sensor.
<b>Wireless Sensor and Touchpad Batteries</b>		
	System indicates <i>Sensor/Touchpad nn low battery</i> .	Replace the indicated device battery. Test the sensor/touchpad after replacing the battery.
		<p><b>Note</b>  <i>If the sensor/touchpad is not tested after battery replacement, the system continues to show a low battery condition, since that was the last signal it received from the device. Testing the sensor/touchpad with new batteries allows the panel to receive a signal with good battery information.</i></p>
<b>Central Station/Pager Reporting</b>		
	Central station/pager is not receiving reports.	<ol style="list-style-type: none"> <li>1. Check that the premises phone line is working.</li> <li>2. Perform a phone test.</li> <li>3. Check that the DB-8 cord is plugged into the RJ-31X/CA-38A jack.</li> <li>4. Check that the DB-8 cord is wired correctly to the panel.</li> <li>5. Check for correct phone line wiring between the TELCO block and RJ-31X/CA-38A jack.</li> <li>6. Replace faulty RJ-31X/CA-38A jack.</li> <li>7. Replace faulty DB-8 cord.</li> <li>8. Verify that central station/pager phone number is programmed into the panel. Reprogram the phone number and retest, if necessary.</li> <li>9. Verify that the correct phone format (SIA or CID) is being used.</li> <li>10. For pagers, extend the pager delay setting (see the <i>PHONE OPTIONS—GLOBAL</i> menu in the "Programming" section).</li> </ol>
<b>Alphanumeric Touchpads</b>		
	Display shows all *****.	Touchpad is not connected to panel bus terminals or is wired incorrectly. Check and correct wiring.
	Display is blank.	

Feature	Problem	Action/Solution
		<ol style="list-style-type: none"> <li>1. Check that panel is powered up.</li> <li>2. Check for touchpad power and/or bus miswiring, opens, or shorts.</li> <li>3. Check touchpad brightness setting (see the user-programming <i>OPTIONS</i> menu in the “Programming” section).</li> </ol>
	Touchpad buttons don’t beep when pressed.	
		<ol style="list-style-type: none"> <li>1. Check for touchpad power and/or bus miswiring, opens, or shorts.</li> <li>2. Check that key beeps option is set to on (see the <i>ACCESSORY MODULES—BUS DEVICES</i> menu in the “Programming” section).</li> </ol>
<b>Fixed Display Touchpads</b>		
	Display is lit but does not respond to key presses.	
		<ol style="list-style-type: none"> <li>1. Touchpad is not connected to panel bus terminals or is wired incorrectly. Check and correct wiring.</li> <li>2. Check that touchpad is learned into panel memory.</li> </ol>
	Display is blank.	
		<ol style="list-style-type: none"> <li>1. Check that panel is powered up.</li> <li>2. Check for touchpad power and/or bus miswiring, opens, or shorts.</li> <li>3. Check touchpad brightness setting (see the user-programming <i>OPTIONS</i> menu in the “Programming” section).</li> </ol>
	Touchpad buttons don’t beep when pressed.	
		<ol style="list-style-type: none"> <li>1. Check for touchpad power and/or bus miswiring, opens, or shorts.</li> <li>2. Check that key beeps option is set to on (see the <i>ACCESSORY MODULES—BUS DEVICES</i> menu in the “Programming” section).</li> </ol>
<b>Speakers</b>		
	Speakers don’t sound alarms.	
		<ol style="list-style-type: none"> <li>1. Check for correct wiring at speaker and panel terminals; correct where necessary.</li> <li>2. Speaker output has shut down because panel detected terminal 7 or 8 is shorted to ground. Disconnect panel AC and battery backup power. Locate short and correct. Apply panel AC and backup battery power and retest.</li> <li>3. Alarm is in partition 2-6 and speaker is connected to panel terminals 7 and 8, which activate only for partition 1 alarms.</li> </ol>
<b>Sirens</b>		
	Piezo sirens connected to SnapCard, or onboard (panel) outputs 1 and/or 2 don’t produce any alarm sounds.	
		<ol style="list-style-type: none"> <li>1. Check for incorrect wiring between siren and panel; correct where necessary.</li> <li>2. Output has not been configured (set up) to activate sirens. Enter program mode and configure output (see <i>ACCESSORY MODULES—BUS DEVICES—SNAP CARD, or ONBOARD OPTIONS—OUTPUT 1, 2</i> in the “Programming” section).</li> <li>3. Check for correct output partition assignment.</li> </ol>
<b>Hardwire Zones</b>		
	System doesn’t go into alarm when zone is tripped.	
		<ol style="list-style-type: none"> <li>1. System is disarmed. Arm system and then trip the zone.</li> <li>2. Zone is not learned into panel memory. Enter installer/dealer program mode—<i>LEARN SENSORS</i>, and learn zone into memory.</li> <li>3. Zone is learned into wrong partition. Delete zone and learn into correct partition or change the partition in the <i>EDIT SENSORS</i> menu.</li> <li>4. For HIM zones, check that the HIM LED is blinking to verify communication with the panel. If LED is off, check wiring between HIM and panel.</li> </ol>
	Zone reports trouble condition.	
		<ol style="list-style-type: none"> <li>1. Check that onboard, HIM, and SnapCard zone inputs have a 2k-ohm EOL resistor installed at the last device on the loop in series for N/C loops, in parallel for N/O loops.</li> <li>2. Check for zone wire fault—short circuit on N/C loops, open circuit on N/O loops.</li> <li>3. Make sure all devices on zone are in non-alarm state, then enter disarm command to reset zone.</li> </ol>
<b>Wireless Sensor Zones</b>		
	System doesn’t respond (in sensor test or when armed) when sensor is tripped.	

Feature	Problem	Action/Solution
		<ol style="list-style-type: none"> <li>1. Verify that receiver antennas are routed through holes on top of enclosure and antenna shrouds are installed.</li> <li>2. Check that the wireless sensor battery(s) are installed.</li> <li>3. Check the sensor battery(s) for low voltage. Replace battery(s) if necessary.</li> <li>4. Use an RF Sniffer (60-401) to verify that sensor is transmitting.</li> <li>5. Sensor is not learned into panel memory. Enter installer/dealer program mode—<i>LEARN SENSORS</i>, and learn sensor into memory.</li> <li>6. Zone is learned into wrong partition. Delete zone and learn into correct partition or change the partition in the <i>EDIT SENSORS</i> menu.</li> </ol>
	Sensor reports trouble condition.	<ol style="list-style-type: none"> <li>1. Sensor tamper switch is tripped—sensor cover is off, not latched securely, or sensor is not mounted securely. Secure sensor mounting and/or cover, then trip sensor to clear the condition.</li> <li>2. Check the sensor battery for low voltage. Replace batteries, if necessary.</li> </ol>
	Touchpad indicates [sensor #] supervisory and/or Sensor [sensor #] supervisory is heard.	<ol style="list-style-type: none"> <li>1. Use an RF Sniffer (60-401) to verify that sensor is transmitting. If sensor is not transmitting, check battery for low or no voltage and replace.</li> <li>2. Change mounting position of sensor (from horizontal to vertical or vice versa) and test sensor several times for consistency.</li> <li>3. Sensor signal is not reaching panel/receiver because sensor is too far away. Remove sensor from mounted location and test from other locations. Mount sensor in area where signal can reach panel/receiver or install a SuperBus 2000 RF Transceiver in the vicinity of the sensor.</li> </ol>
	Smoke sensor beeps once every 44 seconds.	Sensor batteries are getting low. Replace batteries.
<b>Wireless Touchpads</b>		
	System doesn't respond to commands entered from wireless touchpad.	<ol style="list-style-type: none"> <li>1. Verify that receiver antennas are routed through holes on top of enclosure and antenna shrouds are installed.</li> <li>2. Check that touchpad battery(s) are properly installed.</li> <li>3. Check the touchpad battery(s) for low voltage. Replace battery(s), if necessary.</li> <li>4. Use an RF Sniffer (60-401) to verify that touchpad is transmitting.</li> <li>5. Touchpad is not learned into panel memory. Enter program mode and learn touchpad into memory (see <i>LEARN SENSORS</i>).</li> <li>6. Touchpad is learned into wrong partition. Delete touchpad and learn into correct partition or change the partition in the <i>EDIT SENSORS</i> menu.</li> </ol>
	Touchpad reports trouble condition.	Check the touchpad battery(s) for low voltage. Replace battery(s), if necessary.
<b>Phones</b>		
	Loss of dial tone at on-site phones after wiring RJ-31X jack or connecting the DB-8 cord.	<ol style="list-style-type: none"> <li>1. Wait 2 minutes and try again. The panel may be busy trying to report to the central station.</li> <li>2. Disconnect the panel DB-8 cord from the RJ-31X jack. If the phone still doesn't work, the system is okay and the problem is in the wiring.</li> <li>3. Check RJ-31X jack wiring and TELCO block wiring. Replace RJ-31X jack if necessary.</li> <li>4. Check DB-8 cord connections at the panel and RJ-31X jack. Replace cord if necessary.</li> <li>5. Perform a phone test after troubleshooting the phone line.</li> </ol>
	Constant dial tone, preventing dial-out on premises phones.	One or more polarity-sensitive phones exist on-site. Reverse the phone wires connected to the brown and gray wire terminals on the RJ-31X jack.
<b>Light Control</b>		
	Light controlled by X10 Lamp Module is not working.	

Feature	Problem	Action/Solution
		<ol style="list-style-type: none"> <li>1. Check that the lamp has a working bulb and that the lamp switch is on.</li> <li>2. Check to make sure X10 module is not plugged into an outlet controlled by a switch. Move to a nonswitched outlet location and test.</li> <li>3. Panel is not powered by a power line carrier transformer. Replace existing transformer with a power line carrier transformer.</li> <li>4. Power transformer and X10 modules are not plugged into outlets on the same electrical phase. Relocate modules or transformer to different outlets to determine working locations.</li> <li>5. Check that the HOUSE dial on the X10 module matches the partition house code programmed into the panel.</li> <li>6. X10 module is located in wrong partition. Move module to correct partition and retest.</li> <li>7. Partition house codes are not programmed into panel. Enter program mode and set partition house codes.</li> </ol>
<b>Energy Saver Module</b>		
	Module does not respond to system commands or appear to control furnace.	<ol style="list-style-type: none"> <li>1. Check that the module is wired correctly to the panel terminals.</li> <li>2. Verify the module LED is flashing continuously. If the LED is not flashing, remove power and check wiring.</li> <li>3. There is a 5-minute delay after the module returns control to the furnace/AC thermostat, before the module overrides the thermostat again. Wait 5-minutes and try again.</li> </ol>
	Module temperature does not match actual room temperature.	<p>The module room temperature setting has not been adjusted or was adjusted before the module warmed or cooled to room temperature. To ensure accuracy, wait at least 15 minutes after installing the module before adjusting the temperature. To adjust the module room temperature setting, see <i>TEMPERATURE</i> under the <i>ACCESSORY MODULES—BUS DEVICES—UNIT-ID—ENERGY OPTIONS</i> menu in the section “Programming the Panel.”</p>
<b>Automation Module</b>		
	Module is not controlling or communicating with the panel and panel indicates a “ <i>BUS FAILURE UNIT nn</i> ” where nn is the Automation Module bus unit number.	<ol style="list-style-type: none"> <li>1. Check that the module is wired correctly to the panel terminals.</li> <li>2. Verify the SuperBus Module’s red LED is flashing continuously. If the LED is not flashing, remove power and check wiring.</li> </ol>
	Module is not controlling or communicating with the panel and panel indicates a “ <i>BUS FAILURE UNIT AMnn</i> ” where nn is the Automation Module bus unit number.	<ol style="list-style-type: none"> <li>1. Check that the RS-232 cable is firmly connected to the Automation Module and the Automation Device.</li> <li>2. Verify the Automation Device is powered and turned on.</li> </ol>
	Module is not controlling or communicating with the panel and panel does not indicate a bus failure.	Verify the Automation Module is learned into panel memory.
<b>Cellular Backup Module</b>		
	Cellular backup report does not occur.	<ol style="list-style-type: none"> <li>1. Verify the Cellular Backup option is on for the CS phone number being tested.</li> <li>2. Verify that the module is learned into panel memory.</li> <li>3. Check that the Cellular Backup Module has been activated as outlined in the device Installation Instructions.</li> </ol>
	The panel indicates “auxiliary phone trouble 1.”	<ol style="list-style-type: none"> <li>1. Check the antenna connection.</li> <li>2. Adjust the antenna positioning for maximum signal.</li> <li>3. Verify Cellular System setting.</li> <li>4. Check that the Cellular Backup Module has been activated as outlined in the device Installation Instructions.</li> </ol>
	The panel indicates “auxiliary phone trouble 2.”	<ol style="list-style-type: none"> <li>1. Check the antenna connection.</li> <li>2. Adjust the antenna positioning for maximum signal.</li> <li>3. Verify Cellular System setting.</li> </ol>
	The panel indicates “auxiliary phone trouble 3.”	

Feature	Problem	Action/Solution
		<ol style="list-style-type: none"> <li>1. Check the antenna connection.</li> <li>2. Adjust the antenna positioning for maximum signal.</li> </ol>
	The panel indicates "auxiliary phone trouble 4."	Contact the cellular provider for details.
	The panel indicates "auxiliary phone trouble 5."	Contact the cellular provider for details.
	The panel indicates "auxiliary phone trouble 6."	Replace the module.
<b>SuperBus 2000 Wireless Gateway Module</b>		
	Module is not communicating on Bus and indicates a "Bus Failure Unit nn". Where nn represents the Wireless Gateway unit number.	<ol style="list-style-type: none"> <li>1. Check that the module is wired correctly to the panel terminals.</li> <li>2. Verify that the module's red Bus LED is flashing. If not, remove power and check all the wiring.</li> </ol>
	Module's status LED's don't turn on after initial power-up.	<ol style="list-style-type: none"> <li>1. Wait 5 - 8 minutes for the module to communicate with alarm.com.</li> <li>2. Access code Lock feature must be turned off to work properly.</li> </ol>
	Module doesn't communicate with alarm.com.	<ol style="list-style-type: none"> <li>1. Check module's status LED's. Refer to the "SuperBus 2000 Wireless Gateway Module" instructions for a description of the LED's.</li> </ol>

# Appendix A: System Planning Worksheets

Customer Name \_\_\_\_\_  
 Address \_\_\_\_\_  
 City \_\_\_\_\_ County \_\_\_\_\_ State \_\_\_\_  
 Zip \_\_\_\_\_ Phone (\_\_\_\_) \_\_\_\_\_

**Table A1: Wireless Devices**

Part No.	Description	Qty.
60-362	Door/Window Sensor	
60-670-95R	SAW Door/Window Sensor	
60-741-95	Micro Recessed Door/Window Sensor	
60-499	Slim Line Door/Window Sensor	
60-688*	Micro Door/Window Sensor	
60-641	Long-Life Door/Window Sensor	
60-461*	Shock Sensor	
60-459*	Sound Sensor	
60-462*	Glass Guard Sensor	
60-506	System Sensor Smoke Sensor	
60-838-95R	2100ARFT Smoke Sensor	
60-848-02-95	ESL 562 Smoke Sensor	
60-460	Rate-of-Rise Heat Sensor	
60-589*	Manual Fire Pull Sensor	
60-504*	Freeze Sensor	
60-452	Pendant Panic Sensor	
60-458	Single Button Panic Sensor	
60-457	Dual Button Panic Sensor	
60-578	Water-Resistant Panic Sensor	
60-511-01-95*	DS924i PIR Motion Sensor	
60-639-95R	SAW Indoor PIR Motion Sensor	
60-639-95R-OD	SAW Outdoor PIR Motion Sensor ( <b>Not for intrusion protection</b> )	
60-703-95	Crystal Indoor PIR Motion Sensor	
60-834-95R	Adjustable Dual technology Sound Sensor	
60-597	HiTech Handheld Wireless Touchpad	
60-607*	2-Button Keychain Touchpad	
60-606*	4-Button Keychain Touchpad	
60-659-95R*	SAW 4-Button Keychain Touchpad	
60-832-95R*	2-Button ELM Keychain Touchpad	

**Table A2: Hardwire Devices**

Part No.	Description	Qty.	mA (Max.)	Sub Total
<b>Hardwire Sensors/Detectors</b>				
N/A	System Sensor models 2400, or 2400TH or ESL series 429AT, 521B or 521BXT		80 mA††	
13-082*	PIR Motion Detector		10 mA	
<b>Sirens</b>				
13-046	Hardwire Exterior Siren		145 mA	
13-949**	Hardwire Interior Siren		85 mA	
13-950**	Piezo Dynamic Exterior Siren		150 mA	
<b>SuperBus 2000/Miscellaneous Components</b>				
60-746-01	2x16 LCD Alphanumeric Touchpad		90 mA	
60-820	Fixed Display LCD Touchpad		65 mA	
60-803	2x20 LCD Alphanumeric Touchpad		120 mA	
60-804	2x20 VFD Alphanumeric Touchpad		120 mA	
60-983	ATP 1000		110 mA	
60-984	ATP 2600		165 mA	
60-985	ATP 2100		165 mA	
600-1013*	GTS 50		300 mA	
60-836	Voice Only Module (with current jumper installed) (with current jumper removed)		300 mA 600 mA	
60-777-01	Phone Interface/Voice Module		600 mA	
600-1025-01-95R	RF Transceiver		55 mA	
60-764-01-95R	RF Receiver (see note)		35 mA	
600-1019	2 Amp Power Supply		N/A	
60-756	4 Input/2 Output SnapCard		185 mA	
60-757	8Z Hardwire Zone Expander SnapCard		230 mA	
60-758	4 Output SnapCard		130 mA	
60-774	Hardwire Input Module		35 mA	
60-770	Hardwire Output Module		180 mA	
60-620-01*	Energy Saver Module		20 mA	
60-850	Cellular Backup Module (standard power)		1600 mA	
60-850-01	Cellular Backup Module (high power)		1900 mA	
60-861	Wireless Gateway-Ready Kit		1600 mA	
60-677*	Interrogator 200 Audio Verification Module		10 mA	
60-783-02*	Automation Module		35 mA	
60-528	Hardwire Interior Speaker		500 mA	
13-060	15-Watt Speaker		500 mA	
Total power consumption:				mA
Total power consumption not to exceed:				1,000 mA

\* These devices not listed, investigated, or verified by UL.

\*\* UL listing applied for.

† Listed, but not tested for compatibility by UL.

†† Total current only for all 2-wire smoke detectors connected to panel 2-wire smoke loop.

**Note**

When installing SuperBus 2000 RF Receiver Modules, the Antenna Tamper feature must be set to off (see REPORTING—GLOBAL in the “Programming” section).



**Table A3: Zone and Sensor Assignments**

No.	RF Zone	Module Bus ID Number	Module Input Number	Group	Partition	Zone/Sensor Text
01						
02						
03						
04						
05						
06						
07						
08						
09						
10						
11						
12						
13						
14						
15						
16						
17						
18						
19						
20						
21						
22						
23						
24						
25						
26						
27						
28						
29						
30						
31						
32						
33						
34						
35						
36						
37						
38						
39						
40						
41						
42						
43						
44						

**Table A3: Zone and Sensor Assignments (Continued)**

No.	RF Zone	Module Bus ID Number	Module Input Number	Group	Partition	Zone/Sensor Text
45						
46						
47						
48						
49						
50						
51						
52						
53						
54						
55						
56						
57						
58						
59						
60						
61						
62						
63						
64						
65						
66						
67						
68						
69						
70						
71						
72						
73						
74						
75						
76						
77						
78						
79						
80						
81						
82						
83						
84						
85						
86						
87						
88						

**Table A3: Zone and Sensor Assignments (Continued)**

No.	RF Zone	Module Bus ID Number	Module Input Number	Group	Partition	Zone/Sensor Text
89						
90						
91						
92						
93						
94						
95						
96						

**Table A4: System Settings Index and Record**

Setting (reference) default	Shortcut No.	Setting
<b>Installer Programming—8 + Installer/Dealer CODE + 00</b>		
24 Hour Tamper Off	06000	
AC Failure Off	06011	
Access Code Lock (On)	0003	
Access Timeout 90 sec	09004	
Account No. 00000	0010-0060	
Activity Timeout 24 hrs	0305	
Alarm Verify Off	06108-06608	
Antenna Tamper Off	06001	
Audio Mode 1	09001	
Audio Verify Off	09000	
Auto Phone Test Off	02001	
Auto Test Reset On	02002	
Auxiliary Panic On	0511-0561	
Aux Power Fail On	06016	
AVM Access Code None	09006	
Back In Service On	06003	
Backup CS Phone 1 On, CS Phone 2-3 Off	01005, 01015, 01025	1 _____ 2 _____ 3 _____
Battery Restoral Off	06006	
Beep Delay 2 sec	09005	
Buffer Control Off	06002	
Buffer Full Report Off	06007	
Bypass Reports Off	06004	
Call Wait Cancel None	02009	
Cancel Message On	02007	
Cellular Backup CS Phone 1 On, CS Phone 2-3 Off	01007, 01017, 01027	1 _____ 2 _____ 3 _____
Cellular System B		
Closing Reports Off	06101 - 06601	
Comm. Failure On	02003	
CS Phone 1-3 None	01000, 01010, 01020	1 _____ 2 _____ 3 _____
Daylight Saving On	0307	

**Table A4: System Settings Index and Record (Continued)**

Setting (reference) default	Shortcut No.	Setting
Dealer Code None	0002	
Delete Sensors None	082	
Dial Tone Detect On	02010	
Dial Abort Delay 30 sec	02006	
Disable Trouble Beeps Off	0701	
Downloader Code 12345	0000	
Downloader Phone No. None	01090	
DTMF Dialing On	02004	
Duress Code None	0016-0066	
Duress Option Off	06103-06603	
Edit Sensors None	083	
Entry Delay 30 sec	0310-0360	
Entry Lights none	0400-0450	
Exception Reports (phones) Off	01003, 01013, 01023	1 _____ 2 _____ 3 _____
Exception Reports (paggers) Off	01033, 01043, 01053, 01063, 01073	1 _____ 2 _____ 3 _____ 4 _____ 5 _____
Exit Delay 60 sec	0311-0361	
Exit Extension On	0013-0063	
Extended Delay 4 min	0312-0362	
Fire Panic On	0510-0560	
Fire Shutdown Off	09002	
Force Armed Off	06104-06604	
Freeze Alarm Off	06106-06606	
Freeze Temp 42	06107-06607	
Global Fire Off	0703	
Ground Fault On	06017	
High Level Reports (phones) CS Phone 1 On, CS Phone 2-3 Off	01001, 01011, 01021	1 _____ 2 _____ 3 _____
High Level Reports (paggers) On	01031, 01041, 01051, 01061, 01071	1 _____ 2 _____ 3 _____ 4 _____ 5 _____
House Code 1B, 2C, 3D, 4E, 5F, 6G	0401-0451	
Immediate Beeps Off	0700	
Installer Code 4321	0001	
Keychain TP Arming Off	0513-0563	
Keychain TP PTN	0006	
Keyswitch Sensor None	0014-0064	
Keyswitch Style Transition	0015-0065	
Latchkey Format Off	06105-06605	
Latchkey Reports (paggers) On	01035, 01045, 01055, 01065, 01075	1 _____ 2 _____ 3 _____ 4 _____ 5 _____
Latchkey Zones None	0500	
Learn Sensors None	080	
Line Fail Delay None	0213	
Local Phone Control On	0210-0260	

**Table A4: System Settings Index and Record (Continued)**

<b>Setting (reference) default</b>	<b>Shortcut No.</b>	<b>Setting</b>
Low CPU Battery On	06005	
Low Level Reports (phones) CS Phone 1 On, CS Phone 2-3 Off	01002, 01012, 01022	1 _____ 2 _____ 3 _____
Low Level Reports (pagers) Off	01032, 01042, 01052, 01062, 01072	1 _____ 2 _____ 3 _____ 4 _____ 5 _____
Manual Mic Gain	09009	
Multi-PTN Arm Off	0005	
Next Phone Test 7 days	0304	
No Activity Off	06102 - 06602	
Open/Close Reports (phones) Off	01004, 01014, 01024	1 _____ 2 _____ 3 _____
Open/Close Reports (pagers) Off	01034, 01044, 01054, 01064, 01074	1 _____ 2 _____ 3 _____ 4 _____ 5 _____
Opening Reports Off	06100-06600	
Onboard Output 1 01614- any audible alarm	11101	
Onboard Output 2 01710 - status & alarm tones	11111	
Output Trip Time 4 sec	0305	
Pager Delay 15 sec	02008	
Pager Partition Assignment 1	01037, 01047, 01057, 01067, 01077	1 _____ 2 _____ 3 _____ 4 _____ 5 _____
Pager Phone 1-5 None	01030, 01040, 01050, 01060, 01070	1 _____ 2 _____ 3 _____ 4 _____ 5 _____
Partition Security On	0004	
Phone Access Key #	0216-0266	
Phone Panic Off	0215-0265	
Phone Test On	02000	
Phone Test Freq. 7 days	0303	
Police Panic On	0512-0562	
Program Report Off	06015	
Quick Arm Off	0011-0061	
Quick Exit On	0012-0062	
Receiver Failure Off	06012	
Remote Access On	0211-0221	
RF Low Battery Rpt Weekly	06013	
RF Supervisory Rpt Weekly	06014	
RF TX Timeout 12 hrs	0302	
Ring/Hang/Ring On	0212-0262	
Reporting Format (SIA/CID) CID	01006, 01016, 01026	1 _____ 2 _____ 3 _____
Sensor Text None	081	
Silent Talkback Off	09003	
Siren Timeout 4 min	0313-0363	
Siren Verify Off	0710	
Sleep Time Off	0314-0364	
Smoke Verify Off	1100	

**Table A4: System Settings Index and Record (Continued)**

Setting (reference) default	Shortcut No.	Setting
SnapCard Output 1 (01400 - keychain touchpad star button activation)	101101	
SnapCard Output 2 (00410 - any audible alarm)	101111	
SnapCard Output 3 (00903 - arming to STAY or AWAY)	101121	
SnapCard Output 4 (01003 - arming to AWAY)	101131	
Star Is No Delay Off	0514-0564	
Streamlining On	01036, 01046, 01056, 01066, 01076	1 _____ 2 _____ 3 _____ 4 _____ 5 _____
Supervisory Time 03:00	0300	
Swinger Limit 1	06015	
System Tamper Off	06109-06609	
Toll Saver On	0214-0264	
TP Panic RPT FMT Off	06010	
Two Trip Error Off	06009	
Two Wire Smoke Off	1101	
UL 98 Options Off	0702	
VOX Gain Range	09008	
VOX Mic Gain	09007	
VOX RX Gain	09010	
Zone Restorals Off	06008	

## Appendix B: Reference Tables

**Table B1: Sensor Group Characteristics**

No.	Name	Application	Alarm	Delay	Restoral	Supervisory	CS Report	Chime (Level 1)	Active Levels
00	Fixed Panic	24-hour audible fixed emergency buttons.	Police	Instant		√	√		1, 2, 3
01	Portable Panic	24-hour audible portable emergency buttons.	Police	Instant			√		1, 2, 3
02	Fixed Panic	24-hour silent fixed emergency buttons.	Silent	Instant		√	√		1, 2, 3
03	Portable Panic	24-hour silent portable emergency buttons.	Silent	Instant			√		1, 2, 3
04	Fixed Auxiliary	24-hour auxiliary sensor, such as Pendant Panic or holdup button.	Auxiliary	Instant		√	√		1, 2, 3
05	Fixed Auxiliary	24-hour auxiliary emergency button. Siren shutoff confirms CS report.	Auxiliary	Instant		√	√		1, 2, 3
06	Portable Auxiliary	24-hour portable auxiliary alert button.	Auxiliary	Instant			√		1, 2, 3
07	Portable Auxiliary	24-hour portable auxiliary button. Siren shutoff confirms CS report.	Auxiliary	Instant			√		1, 2, 3
08	Special Intrusion	Special belongings, such as gun cabinets and wall safes.	Police	Instant	√	√	√		1, 2, 3
09	Special Intrusion	Special belongings (i.e. gun cabinets and wall safes.)	Police	Standard	√	√	√		1, 2, 3
10	Entry/Exit Delay	Entry and exit doors that require a standard delay time.	Police	Standard	√	√	√	√	2, 3
11	Entry/Exit Delay	Garage doors and entrances that require an extended delay time. *	Police	Extended	√	√	√	√	2, 3
12	Entry/Exit Delay	Driveway gates and entrances that require a twice extended delay time. *	Police	Twice Extended	√	√	√	√	2, 3
13	Instant Perimeter	Exterior doors and windows.	Police	Instant	√	√	√	√	2, 3
14	Instant Interior	Interior doors.	Police	Follower	√	√	√		2, 3
15	Instant Interior	Interior PIR motion sensors. *	Police	Follower		√	√		2, 3
16	Instant Interior	Interior doors.	Police	Follower	√	√	√		3
17	Instant Interior	PIR motion sensors. *	Police	Follower		√	√		3
18	Instant Interior	Instant Interior Cross-Zone# PIR motion sensors. * †	Police	Follower		√	√		3
19	Delayed Interior	Interior doors that initiate a delay before going into alarm. *	Police	Standard	√	√	√		3
20	Delayed Interior	PIR motion sensors that initiate a delay before going into alarm. *	Police	Standard		√	√		3
21	Local Instant Interior	24-hour local alarm zone protecting anything that opens and closes.	Police	Instant	√	√			1, 2, 3
22	Local Delayed Interior	Same as group 21, plus activation initiates a delay before going into alarm.	Police	Standard	√	√			1, 2, 3
23	Local Instant Auxiliary	24-hour local alarm zone protecting anything that opens and closes. ‡	Auxiliary	Instant	√	√			1, 2, 3
24	Local Instant Auxiliary	24-hour local alarm zone protecting anything that opens and closes. Sirens shut off at restoral. *	Auxiliary	Instant	√	√			1, 2, 3
25	Local Special Chime	Notify the user when a door is opened. Sounds emit from a local annunciator. *	Special Chime	Instant		√			1, 2, 3

**Table B1: Sensor Group Characteristics (Continued)**

No.	Name	Application	Alarm	Delay	Restoral	Supervisory	CS Report	Chime (Level 1)	Active Levels
26	Fire	24-hour fire, rate-of-rise heat, and smoke sensors.	Fire	Instant	√	√	√		1, 2, 3
27	Output Module	Hardwire Output Module (HOM) lamp control or other customer feature. ‡	Silent	Instant	√	√			1, 2, 3
28	Output Module	HOM, PIR motion sensor, sound sensor or pressure mat. ‡	Silent	Instant		√			1, 2, 3
29	Auxiliary	Freeze sensor.	Auxiliary	Instant	√	√	√		1, 2, 3
32	Output Module	HOM, PIR motion sensor, sound sensor or pressure mat. ‡	Silent	Instant					
33	Siren	Wireless Siren Supervision. ‡	Silent	Instant		√	√		1, 2, 3
34	Gas	Carbon monoxide (CO) Gas Detectors ‡	Auxiliary	Instant	√	√	√		1, 2, 3
35	Local Instant Police (Day Zone)	Local alarm in levels 1 and 2. Report to CS in level 3.	Police	Instant	√	√	√ (level 3 only)		1, 2, 3
38	Auxiliary	Water sensor ‡	Auxiliary	Instant	√	√	√		1, 2, 3

**Note:** Check marks (√) represent characteristics present in a group.  
 \* This group is not certified as a primary protection circuit for UL-listed systems and is for supplementary use only.  
 † Sounds instant police siren if two or more sensors are tripped within 4 minutes. Otherwise sensors are followers to delayed sensors. If Alarm Verification is on, group 18 functions like group 17.  
 ‡ This group has not been investigated by UL.  
 § This group is required for UL-listed residential fire alarm applications.

**Cross-Zoning**

**Note**  
 Cross-Zoning is not recommended for exit/entry zones. Each zone has the ability to individually protect the intended area. (e.g. motion detector patterns overlap).

Cross-Zone (Alarm Verify) refers to two different Group 10-20 sensors that must be tripped within four minutes of each other to report an alarm to the central station. The diagram in the figure below shows the path of a person walking from the kitchen to the living room. When the person is detected walking through the kitchen, the motion sensor in the kitchen is tripped, sounding a local alarm. If motion is detected by the living room motion sensor within four minutes, an alarm report will be sent to the central station.

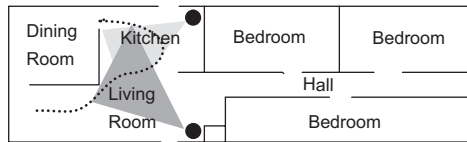

- ▼ Detection Path/Kitchen Motion Sensor
- ▲ Detection Path/Living Room Motion Sensor
- Motion Sensor
- ..... Path of Person Walking



**Table B2: Item Numbers and Sensor Text**

Item #	Sensor Text	Item #	Sensor Text	Item #	Sensor Text	Item #	Sensor Text	Item #	Sensor Text	Item #	Sensor Text
001	Aborted	041	Date	081	Gas	121	North	161	Siren	201	G
002	AC	042	Daughter's	082	Glass	122	Not	162	Sliding	202	H
003	Access	043	Degrees	083	Goodbye	123	Now	163	Smoke	203	I
004	Active	044	Delay	084	Hallway	124	Number	164	Son's	204	J
005	Activity	045	Den	085	Heat	125	Off	165	Sound	205	K
006	Alarm	046	Desk	086	Hello	126	Office	166	South	206	L
007	All	047	Detector	087	Help	127	OK	167	Special	207	M
008	AM	048	Dining	088	High	128	On	168	Stairs	208	N
009	Area	049	Disarmed	089	Home	129	Open	169	Stay	209	O
010	Arm	050	Door	090	House	130	Opening	170	Supervisory	210	P
011	Armed	051	Down	091	In	131	Panic	171	System	211	Q
012	Arming	052	Download	092	Install	132	Partition	172	Tamper	212	R
013	Attic	053	Downstairs	093	Interior	133	Patio	173	Tempera- ture	213	S
014	Auxiliary	054	Drawer	094	Intrusion	134	Pet	174	Test	214	T
015	Away	055	Driveway	095	Invalid	135	Phone	175	Time	215	U
016	Baby	056	Duct	096	Is	136	Please	176	To	216	V
017	Back	057	Duress	097	Key	137	PM	177	Touchpad	217	W
018	Bar	058	East	098	Kids	138	Police	178	Trouble	218	X
019	Basement	059	Energy Saver	099	Kitchen	139	Pool	179	Unbypass	219	Y
020	Bathroom	060	Enter	100	Latchkey	140	Porch	180	Unit	220	Z
021	Battery	061	Entry	101	Laundry	141	Power	181	Up	221	(space)
022	Bedroom	062	Error	102	Left	142	Press	182	West	222	'(apostrophe)
023	Bottom	063	Exit	103	Level	143	Program	183	Window	223	- (dash)
024	Breezeway	064	Exterior	104	Library	144	Progress	184	Zone	224	_ (underscore)
025	Building	065	Factory	105	Light	145	Quiet	185	0	225	*
026	Bus	066	Failure	106	Lights	146	Rear	186	1	226	#
027	Bypass	067	Family	107	Living	147	Receiver	187	2	227	:
028	Bypassed	068	Father's	108	Load	148	Report	188	3	228	/
029	Cabinet	069	Feature	109	Loading	149	RF	189	4	229	?
030	Canceled	070	Fence	110	Low	150	Right	190	5		
031	Car	071	Fire	111	Lower	151	Room	191	6		
032	Carbon Monoxide	072	First	112	Main	152	Safe	192	7		
033	Central	073	Floor	113	Master	153	Schedule	193	8		
034	Chime	074	Force	114	Mat	154	Screen	194	9		
035	Closed	075	Foyer	115	Medical	155	Second	195	A		
036	Closet	076	Freeze	116	Memory	156	Sensor	196	B		
037	Closing	077	Front	117	Menu	157	Service	197	C		
038	Code	078	Furnace	118	Mother's	158	Shed	198	D		
039	Computer	079	Gallery	119	Motion	159	Shock	199	E		
040	Control	080	Garage	120	No	160	Side	200	F		

**Table B3: System Event Trigger Numbers**

<b>System Event</b>	<b>Description</b>	<b>Trigger No.</b>
Null Trigger (used for direct control)	Activated only by schedule or direct command.	000
Fire Alarm	When Fire sirens are started.	001
Police Alarm	When Police sirens are started.	002
Auxiliary Alarm	When Auxiliary sirens are started.	003
Any Audible Alarm	When any of the above sirens are started.	004
Silent Alarm (sensor groups 2, 3, and duress)	When a group 2 or 3 sensor goes into alarm or when a duress alarm is activated (does not include groups 25, 27, 28, or 32).	005
Any Audible or Silent Alarm	When any alarm is started (does not include groups 25, 27, 28, or 32).	006
HOM Group 27, 28, 32 in Alarm	When a sensor in group 27, 28, or 32 goes into alarm.	007
Major Trouble (phone or receiver failure)	When a receiver failure (S94) or a phone failure (S96) occurs.	008
Arming to STAY or AWAY	When the system is armed to level 2 or 3.	009
Arming to AWAY	When the system is armed to level 3.	010
AVM is Interactive (audio session in progress)	When the central station operator begins listening or talking to the premises.	011
Fail-to-Communicate (panel can't call CS or pager)	When the fail-to-communicate output is activated.	012
AVM Trip (edge)	When an AVM alarm occurs, output is activated momentarily.	013
Keychain Touchpad Star Button-Press	When the star button on a keychain touchpad is pressed.	014
Smoke Power (for resetting 4-wire smoke detectors)	Deactivated when hardwire smoke detectors need to be reset.	015
Exterior Siren	Activated for police or fire alarms.	016
Interior Siren	Activation follows all system noises	017
AVM Trip (pulse)	When an AVM alarm occurs, output is deactivated for 10 ms	018
State of System Status	Follows the state of system status (ready or trouble).	019
Tamper Condition	When any tamper is tripped	020
Closing Report Sent	When a closing report has been successfully transmitted to the central station.	021
Arming to Level 1	When the system is disarmed.	022
Group XX in Alarm	When any sensor in group XX goes into alarm	Table B4
Sensor XX in Alarm	When sensor number XX goes into alarm	Table B5
Sensor XX Open	When sensor number XX is opened	Table B5

**Table B4: Sensor Group Event Trigger Numbers**

Sensor Group	Trigger No.	Sensor Group	Trigger No.
Group 00 in alarm	064	Group 17 in alarm	081
Group 01 in alarm	065	Group 18 in alarm	082
Group 02 in alarm	066	Group 19 in alarm	083
Group 03 in alarm	067	Group 20 in alarm	084
Group 04 in alarm	068	Group 21 in alarm	085
Group 05 in alarm	069	Group 22 in alarm	086
Group 06 in alarm	070	Group 23 in alarm	087
Group 07 in alarm	071	Group 24 in alarm	088
Group 08 in alarm	072	Group 25 in alarm	089
Group 09 in alarm	073	Group 26 in alarm	090
Group 10 in alarm	074	Group 27 in alarm	091
Group 11 in alarm	075	Group 28 in alarm	092
Group 12 in alarm	076	Group 29 in alarm	093
Group 13 in alarm	077	Group 32 in alarm	096
Group 14 in alarm	078	Group 33 in alarm	097
Group 15 in alarm	079	Group 34 in alarm	098
Group 16 in alarm	080	Group 35 in alarm	099
		Group 38 in alarm	102

**Table B5: Sensor Number Event Trigger Numbers**

Sensor Number	State	Trigger No.	State	Trigger No.
Sensor 01	in alarm	129	open	257
Sensor 02	in alarm	130	open	258
Sensor 03	in alarm	131	open	259
Sensor 04	in alarm	132	open	260
Sensor 05	in alarm	133	open	261
Sensor 06	in alarm	134	open	262
Sensor 07	in alarm	135	open	263
Sensor 08	in alarm	136	open	264
Sensor 09	in alarm	137	open	265
Sensor 10	in alarm	138	open	266
Sensor 11	in alarm	139	open	267
Sensor 12	in alarm	140	open	268
Sensor 13	in alarm	141	open	269
Sensor 14	in alarm	142	open	270
Sensor 15	in alarm	143	open	271
Sensor 16	in alarm	144	open	272
Sensor 17	in alarm	145	open	273
Sensor 18	in alarm	146	open	274
Sensor 19	in alarm	147	open	275

**Table B5: Sensor Number Event Trigger Numbers**

<b>Sensor Number</b>	<b>State</b>	<b>Trigger No.</b>	<b>State</b>	<b>Trigger No.</b>
Sensor 20	in alarm	148	open	276
Sensor 21	in alarm	149	open	277
Sensor 22	in alarm	150	open	278
Sensor 23	in alarm	151	open	279
Sensor 24	in alarm	152	open	280
Sensor 25	in alarm	153	open	281
Sensor 26	in alarm	154	open	282
Sensor 27	in alarm	155	open	283
Sensor 28	in alarm	156	open	284
Sensor 29	in alarm	157	open	285
Sensor 30	in alarm	158	open	286
Sensor 31	in alarm	159	open	287
Sensor 32	in alarm	160	open	288
Sensor 33	in alarm	161	open	289
Sensor 34	in alarm	162	open	290
Sensor 35	in alarm	163	open	291
Sensor 36	in alarm	164	open	292
Sensor 37	in alarm	165	open	293
Sensor 38	in alarm	166	open	294
Sensor 39	in alarm	167	open	295
Sensor 40	in alarm	168	open	296
Sensor 41	in alarm	169	open	297
Sensor 42	in alarm	170	open	298
Sensor 43	in alarm	171	open	299
Sensor 44	in alarm	172	open	300
Sensor 45	in alarm	173	open	301
Sensor 46	in alarm	174	open	302
Sensor 47	in alarm	175	open	303
Sensor 48	in alarm	176	open	304
Sensor 49	in alarm	177	open	305
Sensor 50	in alarm	178	open	306
Sensor 51	in alarm	179	open	307
Sensor 52	in alarm	180	open	308
Sensor 53	in alarm	181	open	309
Sensor 54	in alarm	182	open	310
Sensor 55	in alarm	183	open	311
Sensor 56	in alarm	184	open	312
Sensor 57	in alarm	185	open	313
Sensor 58	in alarm	186	open	314
Sensor 59	in alarm	187	open	315
Sensor 60	in alarm	188	open	316
Sensor 61	in alarm	189	open	317

**Table B5: Sensor Number Event Trigger Numbers**

<b>Sensor Number</b>	<b>State</b>	<b>Trigger No.</b>	<b>State</b>	<b>Trigger No.</b>
Sensor 62	in alarm	190	open	318
Sensor 63	in alarm	191	open	319
Sensor 64	in alarm	192	open	320
Sensor 65	in alarm	193	open	321
Sensor 66	in alarm	194	open	322
Sensor 67	in alarm	195	open	323
Sensor 68	in alarm	196	open	324
Sensor 69	in alarm	197	open	325
Sensor 70	in alarm	198	open	326
Sensor 71	in alarm	199	open	327
Sensor 72	in alarm	200	open	328
Sensor 73	in alarm	201	open	329
Sensor 74	in alarm	202	open	330
Sensor 75	in alarm	203	open	331
Sensor 76	in alarm	204	open	332
Sensor 77	in alarm	205	open	333
Sensor 78	in alarm	206	open	334
Sensor 79	in alarm	207	open	335
Sensor 80	in alarm	208	open	336
Sensor 81	in alarm	209	open	337
Sensor 82	in alarm	210	open	338
Sensor 83	in alarm	211	open	339
Sensor 84	in alarm	212	open	340
Sensor 85	in alarm	213	open	341
Sensor 86	in alarm	214	open	342
Sensor 87	in alarm	215	open	343
Sensor 88	in alarm	216	open	344
Sensor 89	in alarm	217	open	345
Sensor 90	in alarm	218	open	346
Sensor 91	in alarm	219	open	347
Sensor 92	in alarm	220	open	348
Sensor 93	in alarm	221	open	349
Sensor 94	in alarm	222	open	350
Sensor 95	in alarm	223	open	351
Sensor 96	in alarm	224	open	352

**Table B6: System Feature Event Trigger Numbers**

Feature	State	Trigger No.
Phone Test	initiated	225
AC Failure	for 15 minutes	226
CPU Low Battery	detected (excluding first minute after power-up)	227
Auto Phone Test	begun	228
Receiver Failure	detected	229
Back In Service	alarm (AC loss, battery drain, then AC restore)	230
Phone Failure	detected	231
Buffer Full	detected	232
Two Trip Error	detected	233
System Tamper	alarm (40 incorrect code entry keystrokes)	237
Freeze	alarm	238
No Activity	alarm	239
Fire Panic	alarm	240
Police Panic	alarm	241
Auxiliary Panic	alarm	242
Opening Report	occurred	243
Closing Report	occurred	244
Latchkey Opening or Closing	occurred	245
Duress	alarm	246
Force Armed Report	occurred	247
Fire in Partition	alarm	248
Recent Closing Report	occurred	249
Sensor Test	entered	251

**Table B7: Response Characteristics**

Response Characteristics	Description
Momentary trip time	The point will remain activated for <i>nn</i> seconds (n is 1-12 seconds). The default is 4 seconds
3 minute trip time	The point will remain activated for 3 minutes
Siren-time trip time	The point will remain activated while the sirens are sounding
Sustained trip time	The point will remain activated for the duration of the event
Siren pattern	The point will activate and deactivate according to the current alarm type: Auxiliary -- fast on/off/on Police -- constant on Fire -- repeating
Trip delay	The point will activate 30 seconds after the trigger event occurs

**Table B8: Response Numbers**

Siren Tracking	Trip Delay	Response Time	Response No.
no	no	momentary	00
no	no	3 minutes <sup>5</sup>	01
no	no	siren time <sup>2</sup>	02
no	no	sustained <sup>3</sup>	03
no	yes <sup>4</sup>	momentary	04
no	yes <sup>4</sup>	3 minutes <sup>5</sup>	05
no	yes <sup>4</sup>	siren time <sup>2</sup>	06
no	yes <sup>4</sup>	sustained <sup>3</sup>	07
yes <sup>1</sup>	no	momentary	08
yes <sup>1</sup>	no	3 minutes <sup>5</sup>	09
yes <sup>1</sup>	no	siren time <sup>2</sup>	10
yes <sup>1</sup>	no	sustained <sup>3</sup>	11
yes <sup>1</sup>	yes <sup>4</sup>	momentary	12
yes <sup>1</sup>	yes <sup>4</sup>	3 minutes <sup>5</sup>	13
yes <sup>1</sup>	yes <sup>4</sup>	siren time <sup>2</sup>	14
yes <sup>1</sup>	yes <sup>4</sup>	sustained <sup>3</sup>	15

**Note**

The mechanical lifetime of the relay may be exceeded if an output is set up for a siren tracking response and a pulsing siren (auxiliary or fire) is active for long time periods. A SnapCard relay output's lifetime expectancy is about 350 total pulsing hours.

**Note**

The trip delay is factory set for 30 seconds and cannot be changed.

**Notes for Table B8: Response Numbers**

1. If an event does not trigger sirens, siren tracking response numbers activate without turning on the output. If sirens are triggered by another event, the output pulses to match the siren. If the siren cadence changes (from police to fire, for example), outputs set up for siren tracking change to match the siren and all pulsing outputs pulse to one common cadence.
2. If an event does not trigger sirens, siren time response times activate outputs only if sirens are active for another reason.
3. If an alarm event does not necessarily require disarming (no activity, closing report, etc.), outputs set up for a sustained response time remain activated until the next arming level change.
4. If an event occurs that activates an output set up for trip delay, the delay and output activation can be canceled by trigger event restoral.
5. Activated outputs set up for a 3-minute response time remain active for the entire three minutes. To deactivate the output before the 3-minute time expires, you must enter program mode or remove panel power. Activated outputs set up for a momentary or 3-minute response time restart if the same trigger event occurs again.

# Appendix C: Settings

## Tier 2 Menus

SYSTEM PROGRAMMING	SECURITY	PARTITION	PHONES	CS PHONE 1	CS PHONE 2	CS PHONE 3
B▼ ▲A	#▼ ▲*★	#▼ ▲*★	#▼ ▲*★	#▼ ▲*★	#▼ ▲*★	#▼ ▲*★
Demo Kit On Off	GLOBAL	PARTITION	CS PHONE 1	CS PHONE 1	CS PHONE 2	CS PHONE 3
B▼ ▲A	#▼ ▲*★	#▼ ▲*★	#▼ ▲*★	#▼ ▲*★	#▼ ▲*★	#▼ ▲*★
Partition 1 Copy	Downloader Code 12345 (0000)	Account Number 00000 (0010 - 0060)	Phone Number None (01000)	Phone Number None (01000)	Phone Number None (01010)	Phone Number None (01020)
B▼ ▲A	B▼ ▲A	B▼ ▲A	B▼ ▲A	B▼ ▲A	B▼ ▲A	B▼ ▲A
Clear Memory	Installer Code 4321 (0001)	Quick Arm On Off (0011 - 0061)	High Lvl Rpts On Off (01001)	High Lvl Rpts On Off (01011)	High Lvl Rpts On Off (01021)	High Lvl Rpts On Off (01031)
B▼ ▲A	B▼ ▲A	B▼ ▲A	B▼ ▲A	B▼ ▲A	B▼ ▲A	B▼ ▲A
Exit Programming	Dealer Code **** (0002)	Quick Exit On Off (0012 - 0062)	Low Lvl Rpts On Off (01002)	Low Lvl Rpts On Off (01012)	Low Lvl Rpts On Off (01022)	Low Lvl Rpts On Off (01032)
#	B▼ ▲A	B▼ ▲A	B▼ ▲A	B▼ ▲A	B▼ ▲A	B▼ ▲A
	Access Code Lock On Off (0003)	Exit Extension On Off (0013 - 0063)	Exception Rpts On Off (01003)	Exception Rpts On Off (01013)	Exception Rpts On Off (01023)	Exception Rpts On Off (01033)
	B▼ ▲A	B▼ ▲A	B▼ ▲A	B▼ ▲A	B▼ ▲A	B▼ ▲A
	Ptn Security On Off (0004)	Keyswitch Sensor None (0014 - 0064)	Open/Close Rpts On Off (01004)	Open/Close Rpts On Off (01014)	Open/Close Rpts On Off (01024)	Open/Close Rpts On Off (01034)
	B▼ ▲A	B▼ ▲A	B▼ ▲A	B▼ ▲A	B▼ ▲A	B▼ ▲A
	Multi Ptn Arm None (0005)	Keyswitch Style Transition State (0015 - 0065)	Backup On Off (01005)	Backup On Off (01015)	Backup On Off (01025)	Backup On Off (01035)
	B▼ ▲A	B▼ ▲A	B▼ ▲A	B▼ ▲A	B▼ ▲A	B▼ ▲A
	Keychain TP Ptn (0006)	Duress Code **** (0016 - 0066)	Reporting Format SIA CID (01006)	Reporting Format SIA CID (01016)	Reporting Format SIA CID (01026)	Reporting Format SIA CID (01036)
			B▼ ▲A	B▼ ▲A	B▼ ▲A	B▼ ▲A
			Cellular Backup On Off (01007)	Cellular Backup On Off (01017)	Cellular Backup On Off (01027)	Cellular Backup On Off (01037)



**PHONES (cont.)**

B▶  
◀A

#▼ ▲\*

PAGER 1	PAGER 2	PAGER 3	PAGER 4	PAGER 5	DOWNLOADER PHONE
#▼ ▲*	#▼ ▲*	#▼ ▲*	#▼ ▲*	#▼ ▲*	#▼ ▲*
Phone Number <u>None</u> (01030)	Phone Number <u>None</u> (01040)	Phone Number <u>None</u> (01050)	Phone Number <u>None</u> (01060)	Phone Number <u>None</u> (01070)	Phone Number <u>None</u> 01090
B▼ ▲A	B▼ ▲A	B▼ ▲A	B▼ ▲A	B▼ ▲A	
High Lvl Rpts <u>On Off</u> (01031)	High Lvl Rpts <u>On Off</u> (01041)	High Lvl Rpts <u>On Off</u> (01051)	High Lvl Rpts <u>On Off</u> (01061)	High Lvl Rpts <u>On Off</u> (01071)	
B▼ ▲A	B▼ ▲A	B▼ ▲A	B▼ ▲A	B▼ ▲A	
Low Lvl Rpts <u>On Off</u> (01032)	Low Lvl Rpts <u>On Off</u> (01042)	Low Lvl Rpts <u>On Off</u> (01052)	Low Lvl Rpts <u>On Off</u> (01062)	Low Lvl Rpts <u>On Off</u> (01072)	
B▼ ▲A	B▼ ▲A	B▼ ▲A	B▼ ▲A	B▼ ▲A	
Exception Rpts <u>On Off</u> (01033)	Exception Rpts <u>On Off</u> (01043)	Exception Rpts <u>On Off</u> (01053)	Exception Rpts <u>On Off</u> (01063)	Exception Rpts <u>On Off</u> (01073)	
B▼ ▲A	B▼ ▲A	B▼ ▲A	B▼ ▲A	B▼ ▲A	
Open/Close Rpts <u>On Off</u> (01034)	Open/Close Rpts <u>On Off</u> (01044)	Open/Close Rpts <u>On Off</u> (01054)	Open/Close Rpts <u>On Off</u> (01064)	Open/Close Rpts <u>On Off</u> (01074)	
B▼ ▲A	B▼ ▲A	B▼ ▲A	B▼ ▲A	B▼ ▲A	
Latchkey Rpts <u>On Off</u> (01035)	Latchkey Rpts <u>On Off</u> (01045)	Latchkey Rpts <u>On Off</u> (01055)	Latchkey Rpts <u>On Off</u> (01065)	Latchkey Rpts <u>On Off</u> (01075)	
B▼ ▲A	B▼ ▲A	B▼ ▲A	B▼ ▲A	B▼ ▲A	
Streamlining <u>On Off</u> (01036)	Streamlining <u>On Off</u> (01046)	Streamlining <u>On Off</u> (01056)	Streamlining <u>On Off</u> (01066)	Streamlining <u>On Off</u> (01076)	
B▼ ▲A	B▼ ▲A	B▼ ▲A	B▼ ▲A	B▼ ▲A	
Ptn Assignment 1 2 3 4 5 6 (01037)	Ptn Assignment 1 2 3 4 5 6 (01047)	Ptn Assignment 1 2 3 4 5 6 (01057)	Ptn Assignment 1 2 3 4 5 6 (01067)	Ptn Assignment 1 2 3 4 5 6 (01077)	

B▶  
◀A **PHONE OPTIONS**

#▼ ▲\*

GLOBAL	PARTITION
#▼ ▲*	#▼ ▲*
Phone Test <u>On</u> Off (02000) B▼ ▲A	Local Phone Ctrl <u>On</u> Off (0210 - 0260) B▼ ▲A
Auto Phone Test <u>On</u> Off (02001) B▼ ▲A	Remote Access <u>On</u> Off (0211 - 0261) B▼ ▲A
Auto Test Reset <u>On</u> Off (02002) B▼ ▲A	Ring/Hang/Ring <u>On</u> Off (0212 - 0262) B▼ ▲A
Comm Failure <u>On</u> Off (02003) B▼ ▲A	Line Fail Delay <u>None</u> (10-240 sec) (0213—Ptn 1 only) B▼ ▲A
DTMF Dialing <u>On</u> Off (02004) B▼ ▲A	Toll Saver <u>On</u> Off (0214 - 0264) B▼ ▲A
Dial Abort Delay <u>30</u> sec (15-45) (02006) B▼ ▲A	Phone Panic <u>On</u> Off (0215 - 0265) B▼ ▲A
Cancel Message <u>On</u> Off (02007) B▼ ▲A	Phone ACC Key <u>#</u> * (0216 - 0266)
Pager Delay <u>15</u> sec (0-30) (02008) B▼ ▲A	
Call Wait Cancel <u>On</u> Off (02009) B▼ ▲A	
Dial Tone Detect <u>On</u> Off (02010)	

B▶  
◀A **TIMERS**

#▼ ▲\*

GLOBAL	PARTITION
#▼ ▲*	#▼ ▲*
Supervisory Time 1:00 - 4:00 (Random) (0300) B▼ ▲A	Entry Delay <u>30</u> sec (30-240) (0310 - 0360) B▼ ▲A
RF Tx Timeout <u>12</u> hours (2-24) (0302) B▼ ▲A	Exit Delay <u>60</u> sec (45-184) (0011 - 0061) B▼ ▲A
Phone Test Freq. <u>7</u> days (1-255) (0303) B▼ ▲A	Extended Delay <u>4</u> min (1-8) (0312 - 0362) B▼ ▲A
Next Phone test <u>7</u> days (1-255) (0304) B▼ ▲A	Siren Timeout <u>4</u> min (1-30) (0313 - 0363) B▼ ▲A
Output Trip Time <u>4</u> sec (1-12) (0305) B▼ ▲A	Sleep Time <u>22:00</u> (00:00-23:50) (0314 - 0364) B▼ ▲A
Activity Timeout <u>24</u> hours (1-42) (0306) B▼ ▲A	No Usage time <u>none</u> (2-255 min) (0315 - 0365)
Daylight Saving <u>On</u> Off (0307)	

B▶  
◀A **LIGHT CONTROL**

#▼ ▲\*

PARTITION
#▼ ▲*
Entry Lights <u>None</u> (3-9) (0400 - 0450) B▼ ▲A
House Code <u>1B 2C 3D 4E 5F 6G</u> (0401 - 0451)

B▶ **TOUCHPAD  
OPTIONS** ◀A

#▼ ▲\*

GLOBAL

#▼ ▲\*

Latchkey Zones  
None (1-96)  
(0500)

B▶ PARTITION ◀A

#▼ ▲\*

Fire Panic  
On Off  
(0510 - 0560)

B▼ ▲A

Auxiliary Panic  
On Off  
(0511 - 0561)

B▼ ▲A

Police Panic  
On Off  
(0512 - 0562)

B▼ ▲A

Keychain TP Arm  
On Off  
(0513 - 0563)

B▼ ▲A

Star is No Delay  
On Off  
(0514 - 0564)

B▶ **REPORTING** ◀A

#▼ ▲\*

GLOBAL

#▼ ▲\*

24-Hour Tamper  
On Off  
(06000)

B▼ ▲A

Antenna Tamper  
On Off  
(06001)

B▼ ▲A

Buffer Control  
On Off  
(06002)

B▼ ▲A

Back In Service  
On Off  
(06003)

B▼ ▲A

Bypass Reports  
On Off  
(06004)

B▼ ▲A

Low CPU Battery  
On Off  
(06005)

B▼ ▲A

Battery Restoral  
On Off  
(06006)

B▼ ▲A

Buffer Full Report  
On Off  
(06007)

B▼ ▲A

Zone Restorals  
On Off  
(06008)

B▼ ▲A

Two Trip Error  
On Off  
(06009)

B▼ ▲A

TP Panic Rpt Fmt  
On Off  
(06010)

B▼ ▲A

AC Failure  
On Off  
(06011)

B▼ ▲A

Receiver Failure  
On Off  
(06012)

B▼ ▲

RF Low Bat Rpt  
Daily Weekly  
(06013)

B▶ PARTITION ◀A

#▼ ▲\*

Opening Reports  
On Off  
(06100 - 06600)

B▼ ▲A

Closing Reports  
On Off  
(06101 - 06601)

B▼ ▲A

No Activity  
On Off  
(06102 - 06602)

B▼ ▲A

Duress Option  
On Off  
(06103 - 06603)

B▼ ▲A

Force Armed  
On Off  
(06104 - 06604)

B▼ ▲A

Latchkey Format  
On Off  
(06105 - 06605)

B▼ ▲A

Freeze Alarm  
On Off  
(06106 - 06606)

B▼ ▲A

Freeze Temp  
42 (40-90)  
(06107 - 06607)

B▼ ▲A

Alarm Verify  
On Off  
(06108 - 06608)

B▼ ▲A

System Tamper  
On Off  
(06109 - 06609)

B▼ ▲A

Report Confirm  
On Off  
(06111 - 06611)

B▶ RF Supv Rpt  
Daily Weekly  
(06014) ◀A

B▶ Swinger Limit  
1 (1-2)  
(06015) ◀A

Ground Fault  
On Off  
(06017)

B▼ ▲A

B▶ Aux Power Fail  
On Off  
(06016) ◀A

B▶ **SIREN OPTIONS** ◀A

#▼ ▲\*

GLOBAL

#▼ ▲\*

Immediate Beeps  
On Off  
(0700)

B▼ ▲A

Disable Trbl Beeps  
On Off  
(0701)

B▼ ▲A

UL 98 Options  
On Off  
(0702)

B▼ ▲A

Global Fire  
On Off  
(0703)

B▼ ▲A

Silent Panic  
On Off  
(0704)

B▶ PARTITION ◀A

#▼ ▲\*

Siren Verify  
On Off  
(0710—Ptn 1 only)

B▶ **SENSORS** ◀A

#▼ ▲\*

LEARN SENSORS (080)

#▼ ▲\*

Sensor Partition  
1 2 3 4 5 6

#▼ ▲\*

Sensor Group  
0

#▼ ▲\*

Trip Sensor  
n

B▶ SENSOR TEXT (081) ◀A

#▼ ▲\*

Text for Sensor  
n

#▼ ▲\*

Sensor n Item 0  
0 -

B▶ DELETE SENSORS (082) ◀A

#▼ ▲\*

#▼ ▲\*

Delete Sensor  
n

#▼ ▲\*A

Delete Sensor n  
Done

B▶ EDIT SENSORS (083) ◀A

#▼ ▲\*

Sn P1 Gnn  
NC/NO/TP  
RF/HW

#▼ ▲\*

Sensor Partition  
n

#▼ ▲\*

Sensor Group  
n

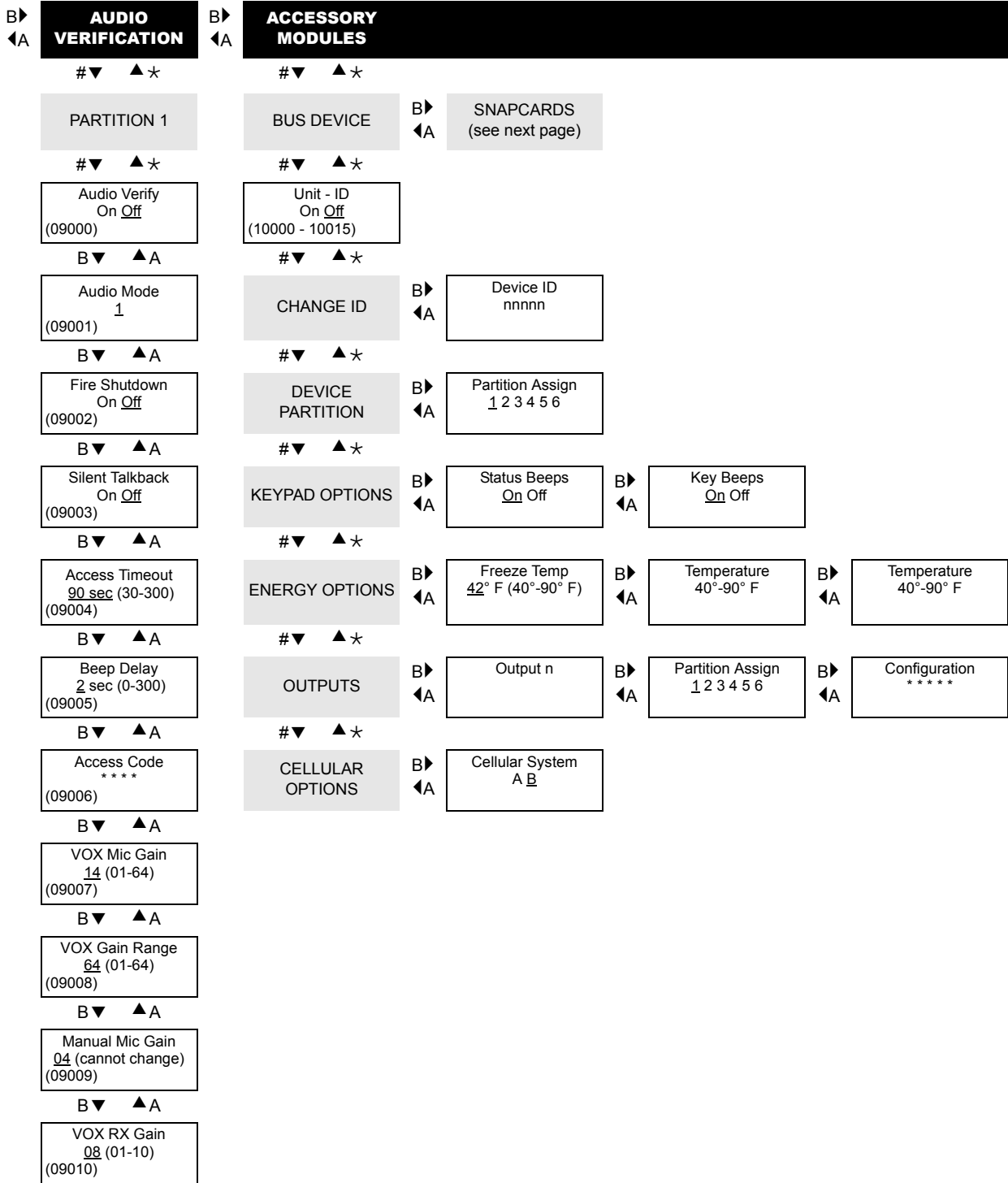

**ACCESSORY MODULES (cont.)**

**B▶**  
**◀A** SNAPCARDS

**ACCESSORY  
MODULES (cont.)**

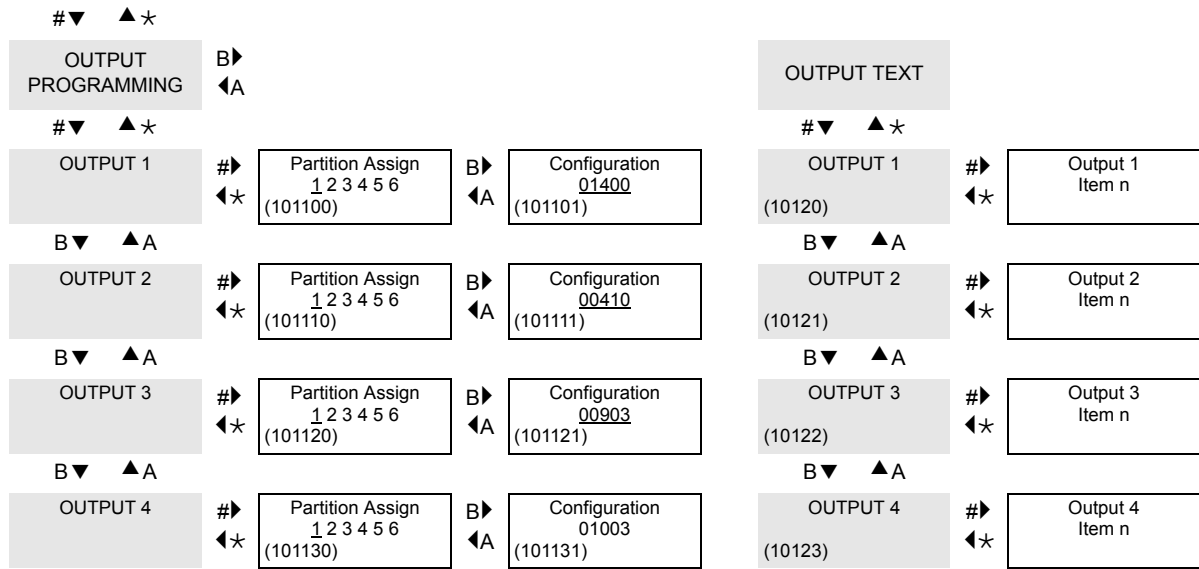

B▶  
◀A **ONBOARD OPTIONS**

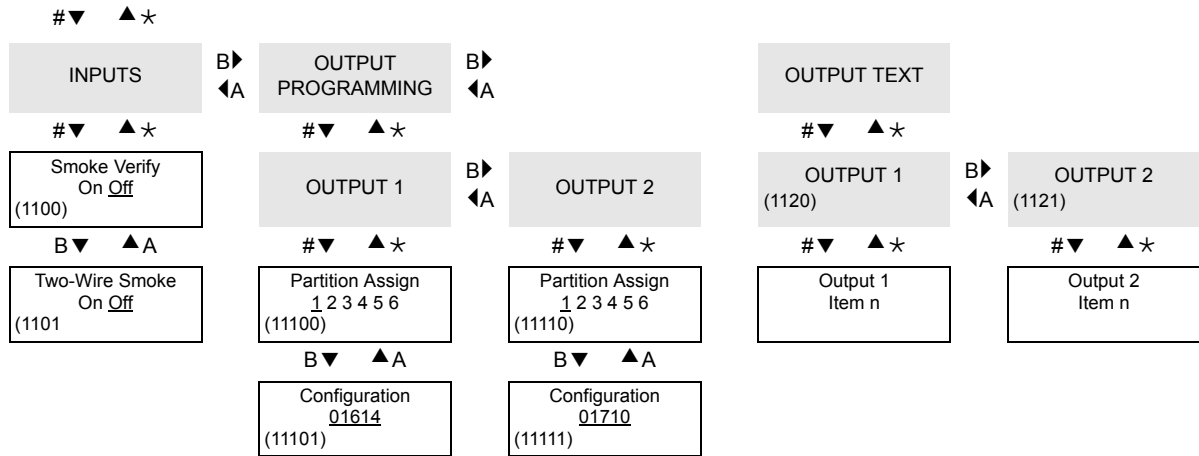

---

## **Appendix D: Software Release Notes**

---

### **Specifications**

**Power Requirements:** .....Class II, 16.5 VAC, 40 VA, 60 Hz (part no. 600-1023 or 600-1024)

**Rechargeable Batteries:** ..12 VDC, 4.5Ah Lead-Acid (part no. 60-681) OR 12 VDC, 7Ah (part no. 60-680). The battery will last 24 hours with no AC and specified standby load

**Radio Frequency:** .....319.5 MHz

**Nominal RF Range:** .....1,000 feet (305 meters) typical open air

**Storage Temperature Range:-** 30° to 140° F (-34° to 60° C)

**Operating Temperature Range:** 32° to 120 ° F (0° to 49° C)

**Maximum Humidity:** .....85% Relative Humidity (non-condensing)

**Auxiliary Power Output:** 1.0 A @ 9 to 14 VDC (12 VDC typical)

**Dimensions:** .....14 in. (35.6 cm) x 12 in. (30.5 cm) x 3.0 in. (7.6 cm) (H x W x D)

---

## System Wiring Notes

### Note 1

Class II power transformer must be plugged into an unswitched AC power receptacle. Do not short the transformer terminals together. The transformer contains an internal fuse that permanently disables the output if the terminals are shorted.

### Note 2

SuperBus 2000 Alphanumeric Touchpads required for on-site programming (models 60-746-01, 60-803, 60-804, 60-983, 60-984, or 60-985). For normal operation and user programming, a SuperBus 2000 Fixed Display Touchpad (60-820) may be used. Maximum 16 bus devices per panel (all partitions).

### Note 3

Speaker terminals 7 and 8 activate only for Partition 1 alarms. Use speakers with an 8-ohm or higher impedance. Use 18-gauge, stranded wire. When connecting two or more 8-ohm speakers, they must be wired in series as shown in the wiring diagram. Wiring two or more 8-ohm speakers in parallel can permanently damage the panel.

### Note 4

Output 1 is +12V switched rated for 1,000 mA (1 amp) maximum. Default configuration number 01614 activates output 30 seconds after a fire or intrusion alarm occurs. Output 2 is open-collector type rated for 300 mA maximum. Default configuration number 01710 activates output for status and alarm sounds. Refer to panel installation instructions for all possible settings.

### Note 5

Zone (loop) wiring shown is an example that applies to all zones (except when zone 8 is configured for 2-wire smoke detectors). Install EOL resistors across all unused zone (loop) inputs.

### Note 6

For UL Listed installations, wire multiple supervised 2-wire hardwire smoke detectors (20 maximum) only as shown. Maximum 120  $\mu$ A current draw per detector. Maximum 90 mA current draw in alarm. See page 12 for tested compatible models.

### Note 7

Some telephones are polarity-sensitive. Green and red wires may need to be reversed.

### Note 8

A maximum of two Audio Verification Modules (60-677) are allowed (Partition 1 only). Wire multiple speakers in series, and power and microphone wires in parallel. Use shielded cable where shown in diagram to prevent cross-talk between the speaker and microphone. Audio Verification Modules shall not be used in UL Listed installations.

### Note 9

Connect multiple piezo sirens in parallel.

### Note 10

Refer to the *SuperBus 2000 Energy Saver Module Installation Instructions* for thermostat wiring details.

### Note 11

Refer to the *SuperBus 2000 4-Relay Output Module Installation Instructions* for device connections to module outputs.

### Note 12

Connect hardwire zones to module inputs the same as those shown for the panel. Install EOL resistors across all unused zone inputs. Refer to the *SuperBus 2000 8Z Module Installation Instructions* for complete details.

### Note 13

Use 60-681—12 VDC, 4.5 Ah or 60-680—12 VDC, 7 Ah backup battery. Battery is automatically tested every 24 hours (every 4 hours with UL 98 Options set to on). Replace only with exact replacement. Without AC power, panel shutdown occurs if battery voltage falls below 10.2 VDC.



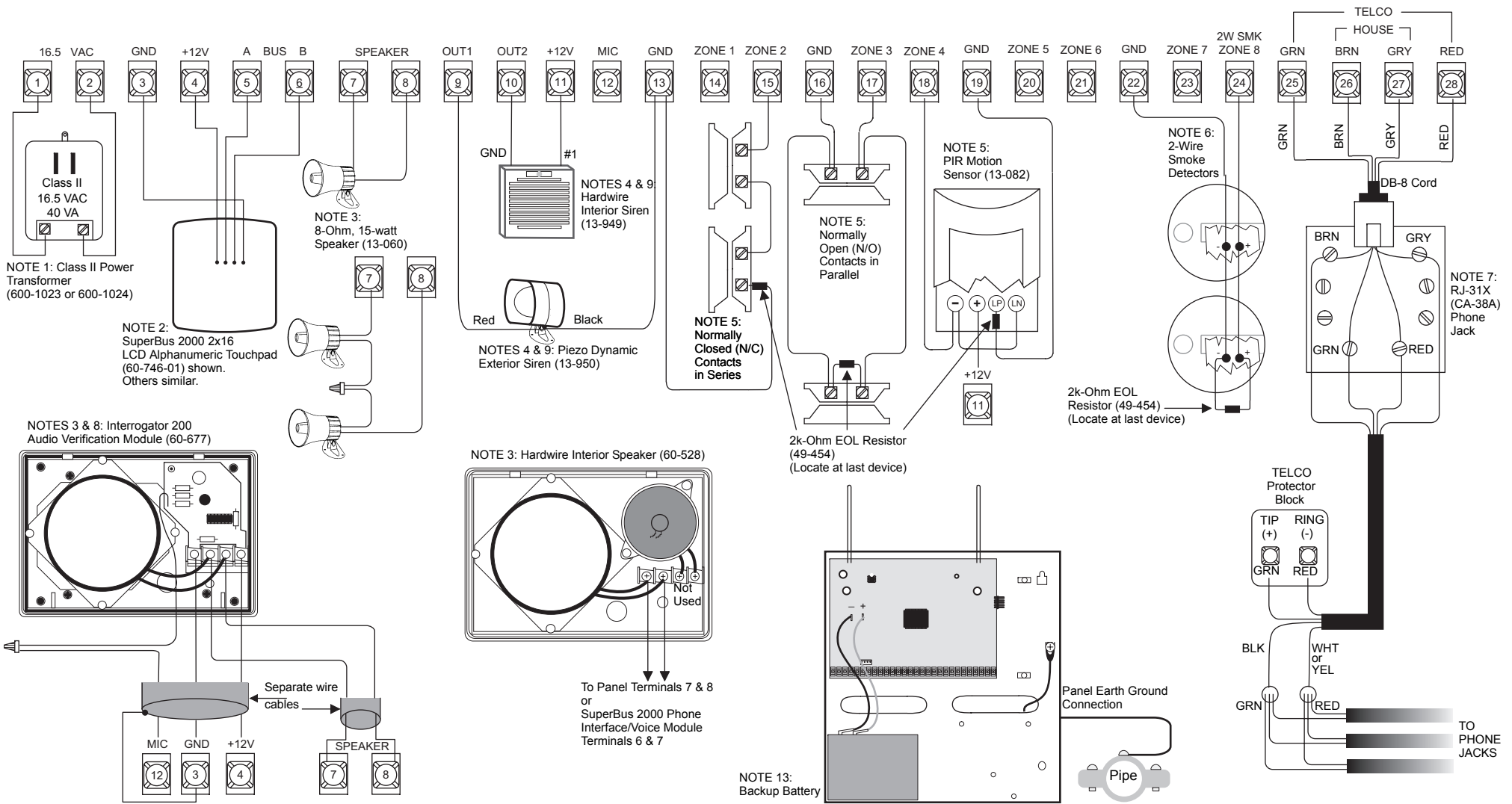

**Other SuperBus 2000 Module Connections**

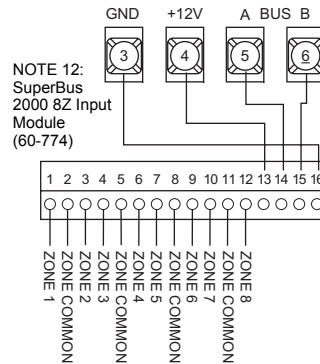
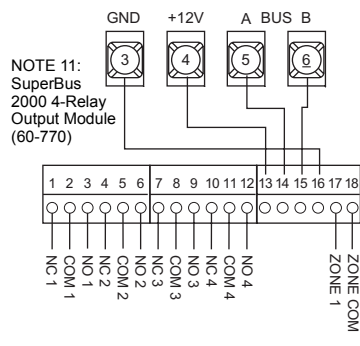
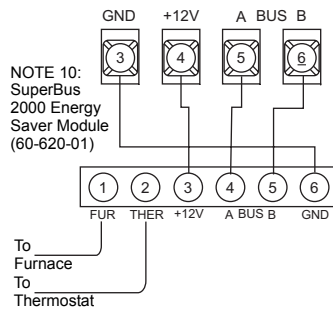

**NOTES 3 & 7: SuperBus 2000 Phone Interface/Voice Module (60-777-01)**

